

EVOLUTION™ SERIES FLOOR BOXES



Wiremold® Evolution™ Series Floor Boxes are the latest advancement in the most complete and innovative line of floor solutions in the industry.



CODE REFERENCE

cULus Listed
Metallic Outlet Boxes:
 File E2961 Guide QCIT.
 Meets Article 314.27(C) of NEC.

Evolution™ Series Floor Box Components

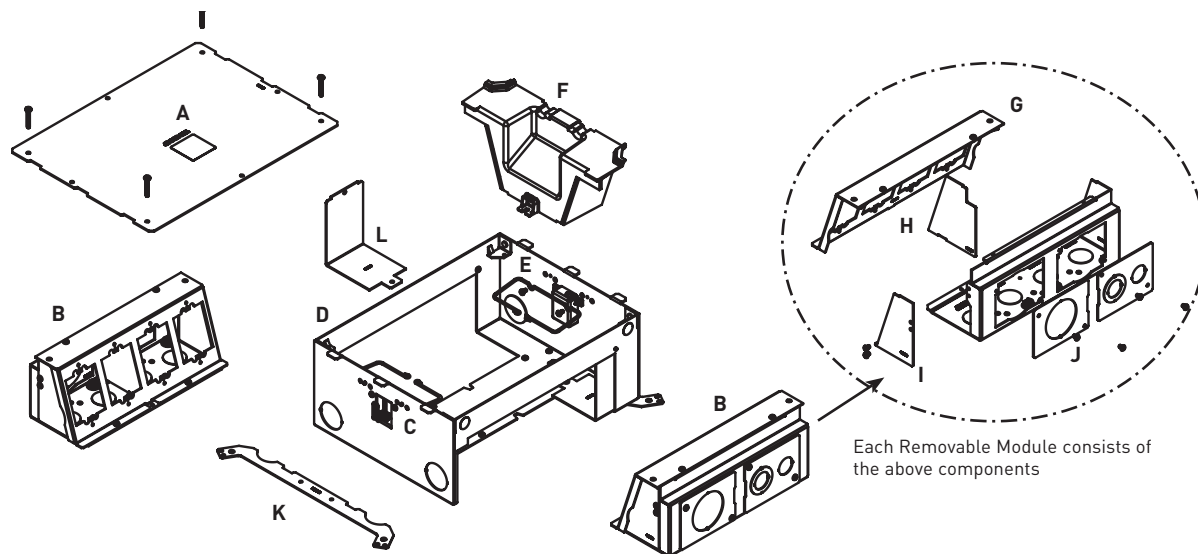

KEY

- | | |
|---|---------------------------------------|
| A. Mud Cap (temporary construction cover) | G. Mounting Bracket |
| B. Removable Module | H. Divider (removable repositionable) |
| C. Toggle Clamp | I. End Cap |
| D. Box | J. Back Knockout Plate |
| E. Cable Guide | K. Concrete Level Leg |
| F. Tunnel | L. "L" Bracket |

All items shown above are included with Evolution Series floor boxes.

COLOR OPTIONS



Evolution Series Floor Box Covers are available in the following powder coated finishes: "BK" black, "GY" gray, "NK" nickel, "BS" brass, and "BZ" bronze.

Custom color options are also available. Consult the factory for more information.

EVOLUTION™ SERIES FLOOR BOXES

Evolution™ Series 8-Gang Floor Box Accessories Ordering Information (continued)

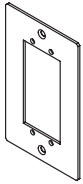
EFB-AAP Device Plate

Holds two (2) Extron® Electronics AAP devices. Device plate dimensions: 2 3/4" x 4 1/2" [69mm x 114mm].

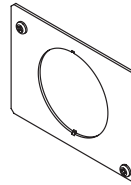
EFB810-2 Knockout Plate

Has one 2" trade size knockout.

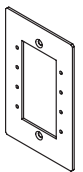
EFB-MAAP Device Plate

Holds four (4) Extron® Electronics MAAP devices. Device plate dimensions: 2 3/4" x 4 1/2" [69mm x 114mm].

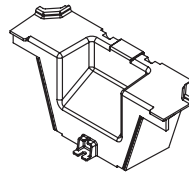
EFB810-TUN Tunnel

For EFB8 Series and EFB10 Series boxes. Tunnel allows cables to be wrapped around box from one module to the other.

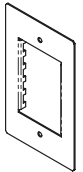
EFB-MOS Device Plate

European device plate accepts up to [45mm x 67.5mm] Arteor device. Device plate dimensions: 2 3/4" x 4 1/2" [69mm x 114mm].

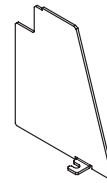
EFB810-DIV Relocatable Divider

Provides separation of services. Includes one (1) divider plate.

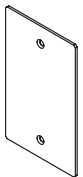
EFB-B Blank Device Plate

Device plate dimensions: 2 3/4" x 4 1/2" [69mm x 114mm].

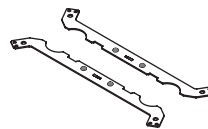
EFB-CLL Concrete Leveling Legs

Concrete Leveling Legs – Legs allow floor box to be adjusted up or down to match the desired pour height of the concrete. Includes two (2) leveling legs. Threaded rod not supplied.

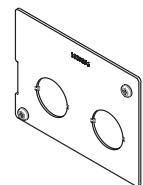
EFB810-3/4-3/4 Knockout Plate

Has two (2) 3/4" trade size knockouts.

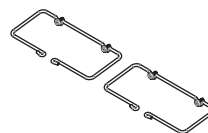
EFBCMG Cable Management Guides

Guides help organize and maintain cable position when opening and closing the cover.

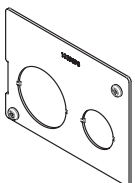
EFB810-3/4-11/4 Knockout Plate

Has one 3/4" and one 3/4"/1 1/4" concentric trade size knockout.

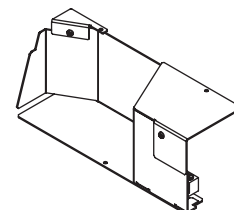
EFB-50A 50A Adapter

Allows for a 50A device to be installed on the 8-gang and 10-gang series boxes.

NOTE: Only fits on the side of the floor box where the device is facing the tunnel.

