

FLOOR BOX SYSTEMS

Quick Selection Guide

Wiremold® Floor Boxes are TopGuard protected to meet and exceed the UL scrub water exclusion requirement.



On-Grade Floor Boxes for Concrete Floors (continued)

EPOXY PAINTED METAL & CAST IRON BOXES										
Box Model	Box Type	Service Capability	Box Capacity	Box Construction	Depth Behind Device Plates	KO Sizes	Cover Model	Cover Construction	Cover & Flange Part Nos.	Notes
Evolution Series EFB8S-OG	Rectangular	Triple	8 Gangs	Steel	3 1/2" [89mm]	3/4" – 2" Trade Size	Evolution Rectangular	Tile, Carpet, Wood, Terrazzo, Polished Concrete	EFB610CTC, EFB610BTC, EFB610BT, EFB610CT	Removable Modules, Standard size Device Plates
Evolution Series EFB10S-OG	Rectangular	Triple	10 Gangs	Steel	3 1/2" [89mm]	1" – 2" Trade Size	Evolution Rectangular	Tile, Carpet, Wood, Terrazzo, Polished Concrete	EFB610CTC, EFB610BTC, EFB610BT, EFB610CT	Removable Modules, Finished Interior
800 Series 800CILCK	Round	Single	1 Gang	Cast Iron	N/A	1/2" – 3/4" Trade Size	Brass	Tile, Carpet	825 Series	Flush Devices, Fully Adjustable
OmniBox 880CS1, 880CM1	Rectangular	Single	1 Gang	Cast Iron	880CS1: 2 3/4" [70mm] 880CM1: 1 3/4" [44mm]	1" Trade Size	Metal, Polycarbonate	Tile, Carpet	817, 818, 828, 829, 830 Series	Flush Devices, Fully Adjustable
OmniBox 880CS2, 880CM2	Rectangular	Dual	2 Gangs	Cast Iron	880CS2: 2 3/4" [70mm] 880CM2: 1 3/4" [44mm]	1" Trade Size	Metal, Polycarbonate	Tile, Carpet	827, 828, 829, 830 Series	Flush Devices, Fully Adjustable
OmniBox 880CS3, 880CM3	Rectangular	Triple	3 Gangs	Cast Iron	880CS3: 2 3/4" [70mm] 880CM3: 1 3/4" [44mm]	1" Trade Size	Metal, Polycarbonate	Tile, Carpet	828, 829, 830, 837, 838 Series	Flush Devices, Fully Adjustable
880 Series 887B/889B	Round	Single	1 Gang	Cast Iron	887: 2" [51mm] 889: 3" [76mm]	887B: 1/2" – 3/4" 889B: 1" – 1 1/4" Trade Size	Metal, Polycarbonate	Tile, Carpet	895, 896 Series	Flush Devices, Fully Adjustable
CCBB Series CCBBS-OG CCBBL-OG	Rectangular	Triple	12 Gangs	Steel	CCBBS-OG: 3 3/4" [95mm] CCBBL-OG: Custom	CCBBS: 3/4" – 2" Trade Size CCBBL: Field Punched	Cast Aluminum	Carpet	CCBBSCTCAL, CCBBLCTCAL	Recessed Devices, Adjustable Pre-pour
CCFB Series	Rectangular	Multi	Customs	Steel	Custom	Field Punched	Cast Aluminum	Tile, Carpet, Bare Concrete	CCFBCTC	Power, A/V, Comm., Water, Air

Above-Grade Floor Boxes for Concrete Floors

PVC BOXES										
Box Model	Box Type	Service Capability	Box Capacity	Box Construction	Depth Behind Device Plates	KO Sizes	Cover Model	Cover Construction	Cover & Flange Part Nos.	Notes
Ratchet-Pro 881	Round	Single	(4) #12 AWG or (6) Cat 6A	PVC	1 3/4" [44mm]	1" Trade Size	Metal, Polycarbonate	Tile, Carpet	895, 896 Series	Flush Devices, On-Grade or Above-Grade
Ratchet-Pro RPNFB	Round	Dual	2 Gang	PVC	3 1/2" [89mm]	3/4" – 2" Trade Size	Metal, Polycarbonate	Tile, Carpet	RPAMD4CTC, RPAMD8CTC, RF4FFCTC, RPAV3CTC, RP9AM2CTC, RP7CTC	Flush Devices, On-Grade or Above-Grade
Modulink 880MPFC	Rectangular	Single	(4) #12 AWG or (6) Cat 6A	PVC	1 3/4" [44mm]	1" Trade Size	Metal, Polycarbonate	Tile, Carpet	817, 818, 828, 829, 830 Series	Flush Devices, On-Grade or Above-Grade
Modulink 880MP2	Rectangular	Single	(4) #12 AWG or (6) Cat 6A	PVC	1 3/4" [44mm]	1/2" – 2" Trade Size	Metal, Polycarbonate	Tile, Carpet	817, 818, 828, 829, 830 Series	Flush Devices, On-Grade or Above-Grade
Modulink 880MP2	Rectangular	Dual		PVC	1 3/4" [44mm]	1/2" – 2" Trade Size	Metal, Polycarbonate	Tile, Carpet	827, 828, 829, 830, 837, 838 Series	Flush Devices, On-Grade or Above-Grade

Fire Classified Floor Boxes – Add "FC" Suffix to part number for fire classified version. All fire classified boxes feed with 1 1/4" conduit feeds.

NOTE: Most Wiremold floor boxes and accessories are listed by Underwriters Laboratories Inc., and comply with Federal Specifications W-C-583b in one of the following types and classes: Type I-Fully adjustable, Type II-Semi-adjustable, Type III-Non-adjustable, Class 1-Watertight, Class 2-Concrete-tight.

EVOLUTION™ SERIES FLOOR BOXES



Wiremold® Evolution™ Series Floor Boxes are the latest advancement in the most complete and innovative line of floor solutions in the industry.



CODE REFERENCE

cULus Listed
Metallic Outlet Boxes:
 File E2961 Guide QCIT.
 Meets Article 314.27(C) of NEC.

Evolution™ Series Floor Box Components

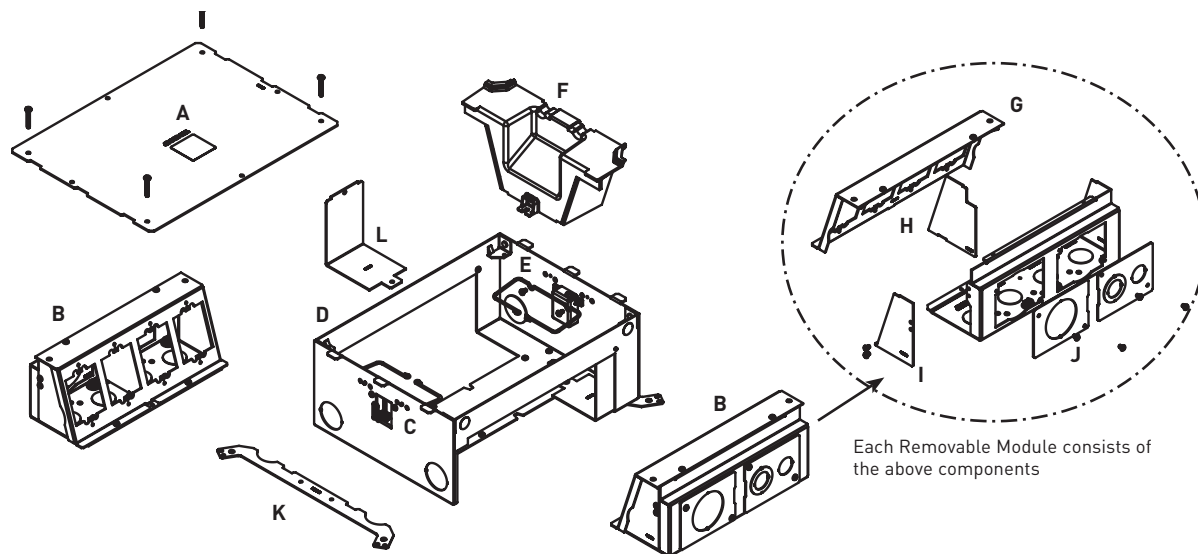

KEY

- | | |
|---|---------------------------------------|
| A. Mud Cap (temporary construction cover) | G. Mounting Bracket |
| B. Removable Module | H. Divider (removable repositionable) |
| C. Toggle Clamp | I. End Cap |
| D. Box | J. Back Knockout Plate |
| E. Cable Guide | K. Concrete Level Leg |
| F. Tunnel | L. "L" Bracket |

All items shown above are included with Evolution Series floor boxes.

COLOR OPTIONS



Evolution Series Floor Box Covers are available in the following powder coated finishes: "BK" black, "GY" gray, "NK" nickel, "BS" brass, and "BZ" bronze.

Custom color options are also available. Consult the factory for more information.

EVOLUTION™ SERIES FLOOR BOXES

Evolution™ Series Floor Box Model Selection Guide

EVOLUTION FLOOR BOX MODEL	EFB6S	EFB6S-OG	EFB6S-FC	EFB8S	EFB8S-OG	EFB8S-FC	EFB10S	EFB10S-OG	EFB10S-FC	EFBFF	EFBFF-OG
INSTALL FLOOR TYPE: Concrete Floor Raised Floor Wood Floor	YES YES YES	YES	YES	YES YES YES	YES	YES	YES YES YES	YES	YES	YES YES YES	YES
BOX TYPE:	Standard	On-Grade	Fire Classified	Standard	On-Grade	Fire Classified	Standard	On-Grade	Fire Classified	Furniture Feed	Furniture Feed
BOX CAPACITY:	6-Gangs	6-Gangs	6-Gangs	8-Gangs	8-Gangs	8-Gangs	10-Gangs	10-Gangs	10-Gangs	2-Gangs	2-Gangs
DEPTH BEHIND PLATES:	3 7/8" [98mm]	3 7/8" [98mm]	3 7/8" [98mm]	3 1/2" [89mm]	3 1/2" [89mm]	3 1/2" [89mm]	3 1/2" [89mm]	3 1/2" [89mm]	3 1/2" [89mm]	N/A	N/A
REMOVABLE MODULES:	YES	YES	YES	YES	YES	YES	YES	YES	YES		
DEVICE PLATE SIZE:	Uses Standard Size Device Plates: Single-Gang [2 3/4" x 4 1/2"] [70mm x 114mm]			Uses Standard Size Device Plates: Single-Gang [2 3/4" x 4 1/2"] Double-Gang [4 9/16" x 4 1/2"] Triple-Gang [6 3/8" x 4 1/2"]			Uses Non-Standard Size Device Plates [4.652" x 2.302"] [117mm x 58mm]				
COVERS: COLORS:	EFB610CTC Series, EFB610BTC Series, EFB610CT Series, EFB610BT Series Black, Gray, Brass, Nickel, Bronze									FPFFTC Series Black, Gray, Brass, Nickel, Bronze, Brushed Aluminum	
FLOOR SURFACE:	Carpet, Tile, Wood, Bare (Polished) Concrete & Terrazzo									Carpet, Tile & Wood	
KO SIZE RANGE: (TRADE SIZE)	3/4" to 2"	3/4" to 2"	1 1/4"	3/4" to 2"	3/4" to 2"	1 1/4"	3/4" to 2"	3/4" to 2"	1 1/4"	1/2" to 2"	1/2" to 2"
FIRE RATING: (HOURS)			Up to 2 Hours			Up to 2 Hours			Up to 2 Hours		

NOTE: Covers open full 180°, slide cable egress doors, painted interior.

Evolution Series Floor Box Compartment Volumes

MODEL	OUTER COMPARTMENTS (EACH)		CENTER COMPARTMENTS (EACH)	
EFB6 SERIES	32 in. ³	[524ml]	38.5 in. ³	[630ml]
EFB8 SERIES	27.5 in. ³	[450ml]	34 in. ³	[557ml]
EFB10 SERIES	23.5 in. ³	[385ml]	27.5 in. ³	[450ml]
EFBFF SERIES	64.5 in. ³	[1056ml]	64.5 in. ³	[1056ml]



Finished Interior

Fully finished interior removes the unfinished industrial look while increasing visibility, making it easier to see where to plug in devices.



Configurable with Removable Modules

In addition to having removable dividers and a tunnel feature that allows all compartments to be connected, the modules are removable through the top or back of the floor box. This allows for easier installations and facilitates moves, adds and changes without having to disconnect services, saving time and money.



Audio/Video Design

Evolution Series Floor Boxes have been developed specifically with the A/V industry in mind. With 3 1/2" – 3 7/8" [89mm x 98mm] of wiring capacity behind each device plate, these boxes will accept devices from leading A/V manufacturers including Extron® Electronics and Crestron®.



Durable 180° Articulating Hinge

Hinge design enables covers to open a full 180° and lie flat on the floor surface with the durability to support a large cover. Provides easy access to all interior modules and activations while reducing tripping hazards.

EVOLUTION™ SERIES FLOOR BOXES

Evolution™ Series 10-Gang Floor Box Ordering Information

EFB10S 10-Gang Floor Box

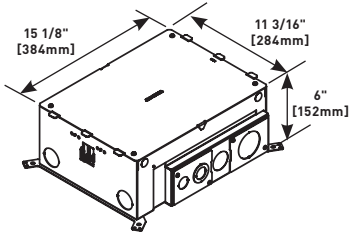

Designed to be installed in concrete floors, raised floors, and wood floor applications. Box has a fully finished interior to assist plugging and unplugging of devices. **Box comes complete with all components needed for initial installation. Included components are:** protective/disposable cover, tunnel system for connecting the two modules of compartments, two (2) removable modules, two (2) toggle clamps to secure box to raised and wood floors, two (2) cable management guides, two (2) leveling support legs for concrete applications, trade size knockouts ranging in size from 3/4" to 2". **Items not included with the box and sold separately are:** receptacles, communication jacks, and A/V devices and device plates. Box is compatible with Wiremold® Walkerflex Modular Wiring System. Custom options are available upon request.

NOTE: For use on bare (polished) concrete or terrazzo floors EFB610-CTR must be used (sold separately).

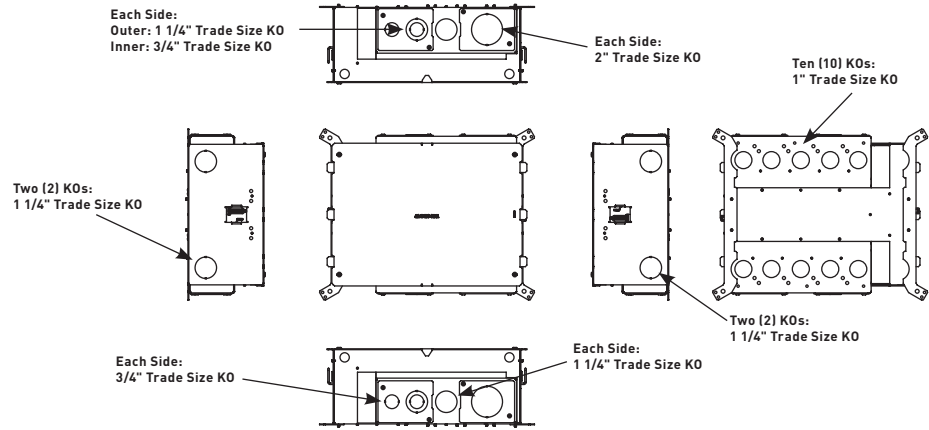
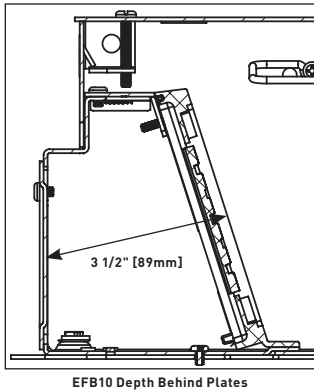

EFB10S-OG 10-Gang Floor Box

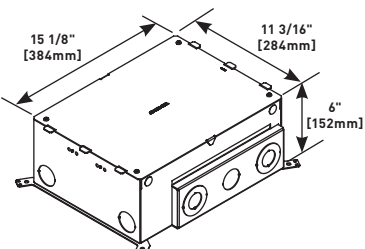

Designed to be installed in both on-grade and above grade concrete floor applications. Box has an epoxy coating that allows the box to be placed in on-grade applications without the need for additional vapor barriers. **Box comes complete with all components needed for initial installation. Included components are:** protective/disposable cover, tunnel system for connecting the two modules of compartments, two (2) removable modules, two (2) cable management guides, two (2) leveling support legs for concrete applications and trade size knockouts ranging in size from 3/4" to 1 1/4". **Items not included with the box and sold separately are:** receptacles, communication jacks, and A/V devices and device plates. Custom options are available upon request.

NOTE: For use on bare (polished) concrete or terrazzo floors EFB610-CTR must be used (sold separately).

