

Metallic — aluminum

Fittings — explaining the fitting styles

A

H-style

H-style fittings constructed with side rail having inner and outer flanges (H-beam).

Features and benefits

- Improved system rigidity
- Improved aesthetics and customer appeal
- Easy to install
- Easy-to-align straights and fittings
- Splice plate holds components together while hardware is inserted
- Premium design
- 3" tangents on fittings
- 7" length snap-in splice plate

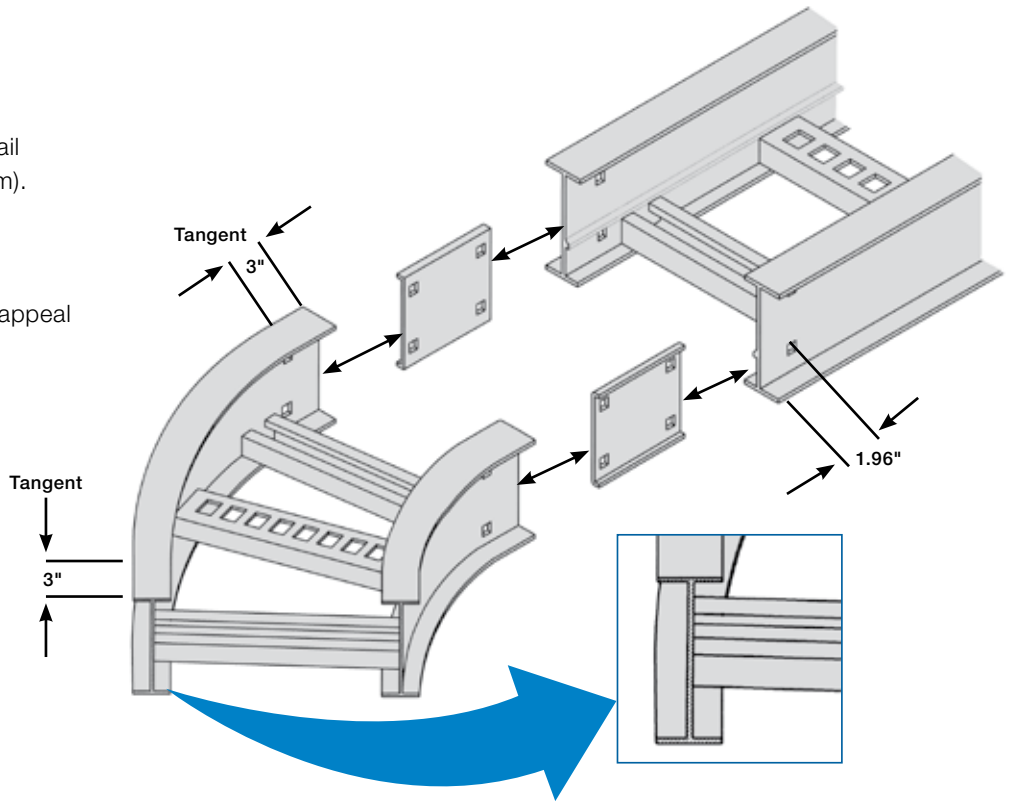

U-style

U-style fittings constructed with side rail flanges on the inside only (U-beam).

Features and benefits

- U-style and H-style are interchangeable
- Lowest purchase price
- Easy to install
- Occupies less space in areas where space is restrained
- Easy-to-align straights
- Splice plate holds components together while hardware is inserted
- Lighter fittings are easy to handle
- Functional design
- 7" length snap-in splice plate

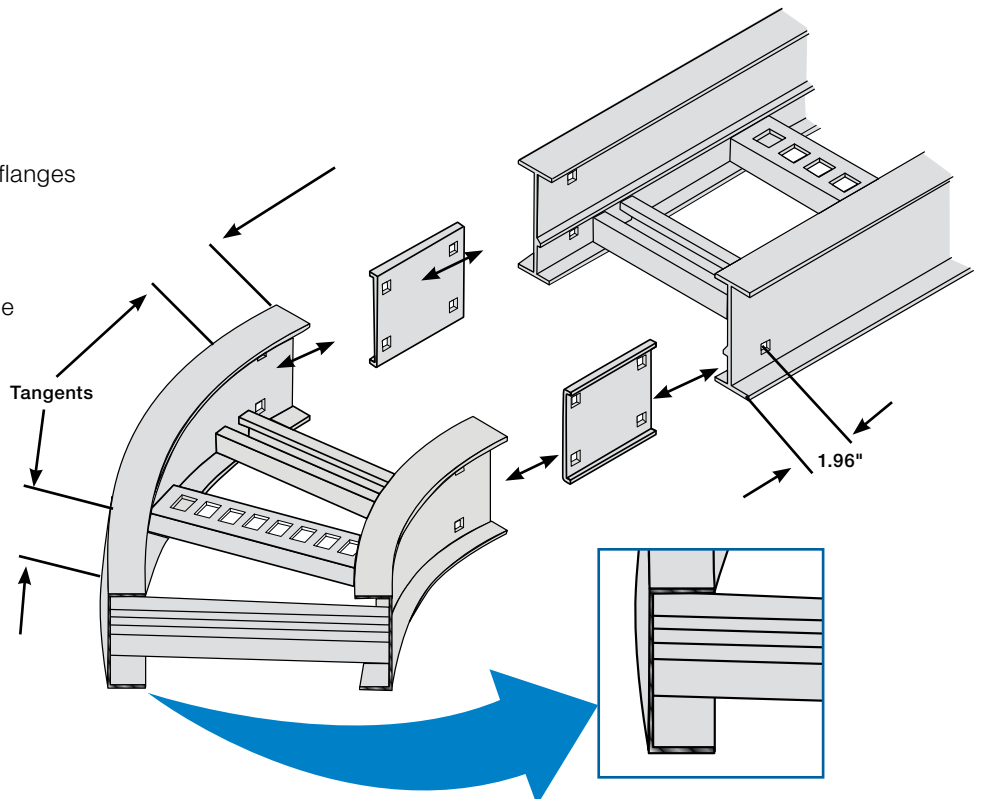

T&B aluminum cable tray is composed of two distinct systems, H-style and U-style. These systems are interchangeable.

Metallic – aluminum

Fittings – horizontal fittings selection

Fittings in a cable tray system are required to change cable routing direction and to join straight sections and other fittings. This step of the cable tray selection process requires that the specifier chooses between two distinct styles, U and H.

Note: The U-style and H-style systems are interchangeable.

H-style fitting

- An H-shaped extrusion forms the fitting side rail.
- H-style fittings utilize a 7" splice plate and the fittings have 3" tangents at the extremities.
- This style offers enhanced aesthetics to the end user and increased system rigidity.

U-style fitting

- A U-shaped extrusion forms the fitting side rail.
- U-style fittings utilize a 7" splice plate and the fittings have tangents at the extremities.
- This style offers maximum quality versus cost ratios of the installation.

Fitting number selection

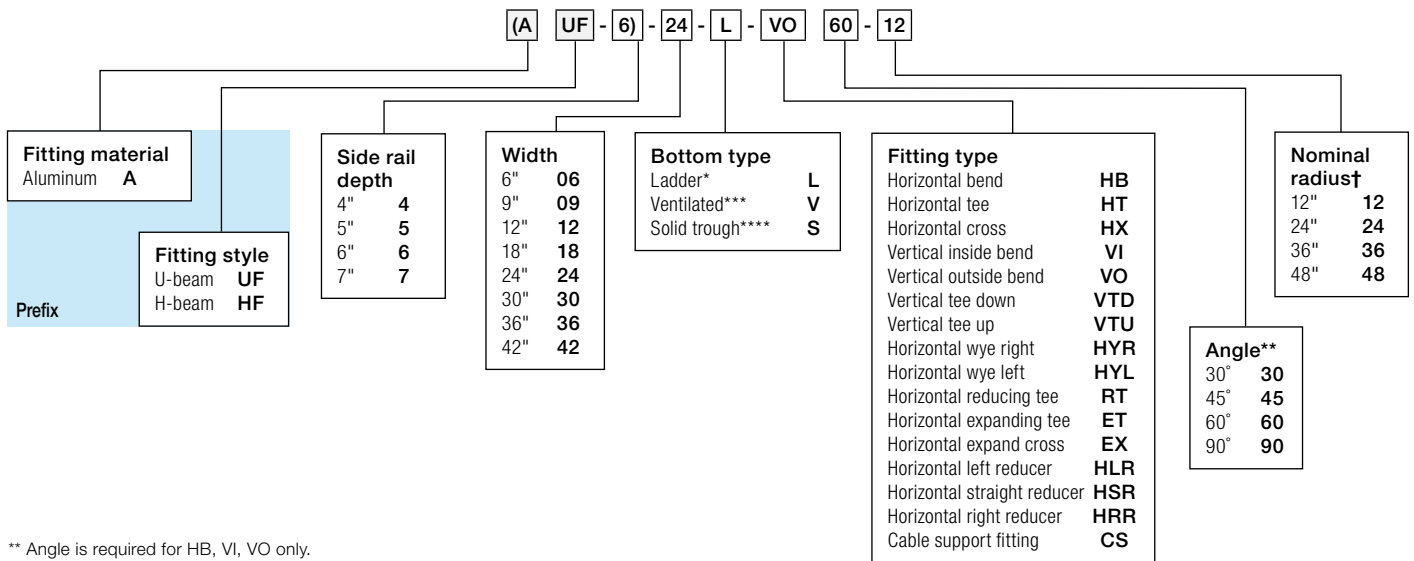

** Angle is required for HB, VI, VO only.

† Radius is not required for the following fitting types: HYR, HYL, HLR, HRR, HSR

* Manufactured with 9" rung spacing measured at the center line of fitting.

*** Manufactured with 4" edge to edge rung spacing measured at the center line of fitting.

**** Manufactured with flat sheet inserted under rungs with 9" rung spacing measured at the center line of fitting.

NOTE: The following special options are available. To order, add the indicated suffix to the very end of the catalog number.

FO = Flange out

G = Ground holes (specify locations and size)

H = Stainless steel type 316 hardware nuts and bolts

MR = Marine rung alternated

UM = Marine rung holes up

RU = Rung with square holes on top

FR = Flat rung

Metallic – aluminum

Fittings – 30° U-style fittings horizontal bends

A

Catalog number system

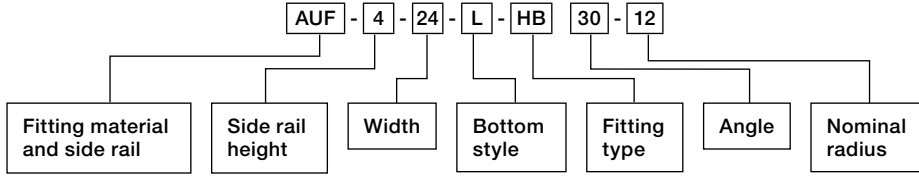

Selection guide

Inside tray widths: 6, 9, 12, 18, 24, 30, 36, 42"

Angle: 45°, 30°

Nominal radius: 12, 24, 36, 48"

Bottom styles: L – ladder, V – ventilated, S – solid

Side rail heights: 4" – 7"

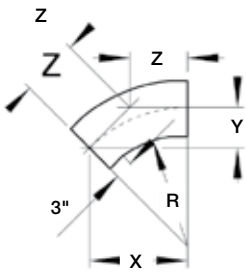

30° Horizontal bend – U-style

Nominal Radius (in.)	Width (in.)	Cat. No.	Dimensions (in.)		
			X	Y	Z
12	6	AUF(t)-06-(*)-HB30-12	11 ¹ / ₈	3 ¹ / ₈	6 ⁵ / ₁₆
	9	AUF(t)-09-(*)-HB30-12	12 ² / ₈	3 ³ / ₁₆	6 ⁵ / ₁₆
	12	AUF(t)-12-(*)-HB30-12	13 ¹ / ₂	3 ¹ / ₂	7
	18	AUF(t)-18-(*)-HB30-12	14 ⁴ / ₈	3 ¹⁵ / ₁₆	7 ¹³ / ₁₆
	24	AUF(t)-24-(*)-HB30-12	16 ¹ / ₈	4 ⁴ / ₁₆	8 ⁵ / ₈
	30	AUF(t)-30-(*)-HB30-12	17 ⁷ / ₈	4 ¹¹ / ₁₆	9 ⁷ / ₁₆
	36	AUF(t)-36-(*)-HB30-12	19 ¹ / ₈	5 ¹ / ₈	10 ¹ / ₄
	42	AUF(t)-42-(*)-HB30-12	20 ⁵ / ₈	5 ¹ / ₂	11 ¹ / ₁₆
24	6	AUF(t)-06-(*)-HB30-24	17 ⁷ / ₈	4 ¹¹ / ₁₆	9 ⁷ / ₁₆
	9	AUF(t)-09-(*)-HB30-24	18 ³ / ₈	4 ¹⁵ / ₁₆	9 ¹³ / ₁₆
	12	AUF(t)-12-(*)-HB30-24	19 ¹ / ₈	5 ³ / ₁₆	10 ¹ / ₁₆
	18	AUF(t)-18-(*)-HB30-24	20 ⁵ / ₈	5 ⁸ / ₁₆	11 ¹ / ₁₆
	24	AUF(t)-24-(*)-HB30-24	22 ¹ / ₈	5 ¹⁵ / ₁₆	11 ¹³ / ₁₆
	30	AUF(t)-30-(*)-HB30-24	23 ³ / ₈	6 ³ / ₁₆	12 ¹⁰ / ₁₆
	36	AUF(t)-36-(*)-HB30-24	25 ¹ / ₈	6 ¹² / ₁₆	13 ⁷ / ₁₆
	42	AUF(t)-42-(*)-HB30-24	26 ⁵ / ₈	7 ¹ / ₈	14 ¹ / ₄
36	6	AUF(t)-06-(*)-HB30-36	23 ³ / ₈	6 ³ / ₁₆	12 ⁵ / ₈
	9	AUF(t)-09-(*)-HB30-36	24 ⁴ / ₈	6 ¹ / ₂	13 ¹ / ₁₆
	12	AUF(t)-12-(*)-HB30-36	25 ¹ / ₈	6 ³ / ₄	13 ⁷ / ₁₆
	18	AUF(t)-18-(*)-HB30-36	26 ⁵ / ₈	7 ¹ / ₄	14 ¹ / ₄
	24	AUF(t)-24-(*)-HB30-36	28 ¹ / ₈	7 ¹ / ₂	15 ¹ / ₁₆
	30	AUF(t)-30-(*)-HB30-36	29 ⁵ / ₈	7 ¹⁵ / ₁₆	15 ⁷ / ₈
	36	AUF(t)-36-(*)-HB30-36	31 ¹ / ₈	8 ⁵ / ₁₆	16 ¹¹ / ₁₆
	42	AUF(t)-42-(*)-HB30-36	32 ² / ₈	8 ³ / ₄	17 ¹ / ₂
48	6	AUF(t)-06-(*)-HB30-48	29 ⁵ / ₈	7 ¹⁵ / ₁₆	15 ⁷ / ₈
	9	AUF(t)-09-(*)-HB30-48	30 ³ / ₈	8 ¹ / ₈	16 ¹ / ₄
	12	AUF(t)-12-(*)-HB30-48	31 ¹ / ₈	8 ³ / ₁₆	16 ¹¹ / ₁₆
	18	AUF(t)-18-(*)-HB30-48	32 ² / ₈	8 ³ / ₄	17 ¹ / ₂
	24	AUF(t)-24-(*)-HB30-48	34 ¹ / ₈	9 ¹ / ₈	18 ¹ / ₄
	30	AUF(t)-30-(*)-HB30-48	35 ⁵ / ₈	9 ⁹ / ₁₆	19 ¹ / ₁₆
	36	AUF(t)-36-(*)-HB30-48	37 ¹ / ₈	9 ¹⁵ / ₁₆	19 ⁷ / ₈
	42	AUF(t)-42-(*)-HB30-48	38 ⁵ / ₈	10 ⁹ / ₁₆	20 ¹¹ / ₁₆

(t) Insert side rail height. (*) Insert bottom style to complete Cat. No. Includes one pair of splice plates with hardware.

T&B aluminum cable tray is composed of two distinct systems, H-style and U-style. These systems are interchangeable.