

## Channels and Concrete Inserts

### Welded Combinations

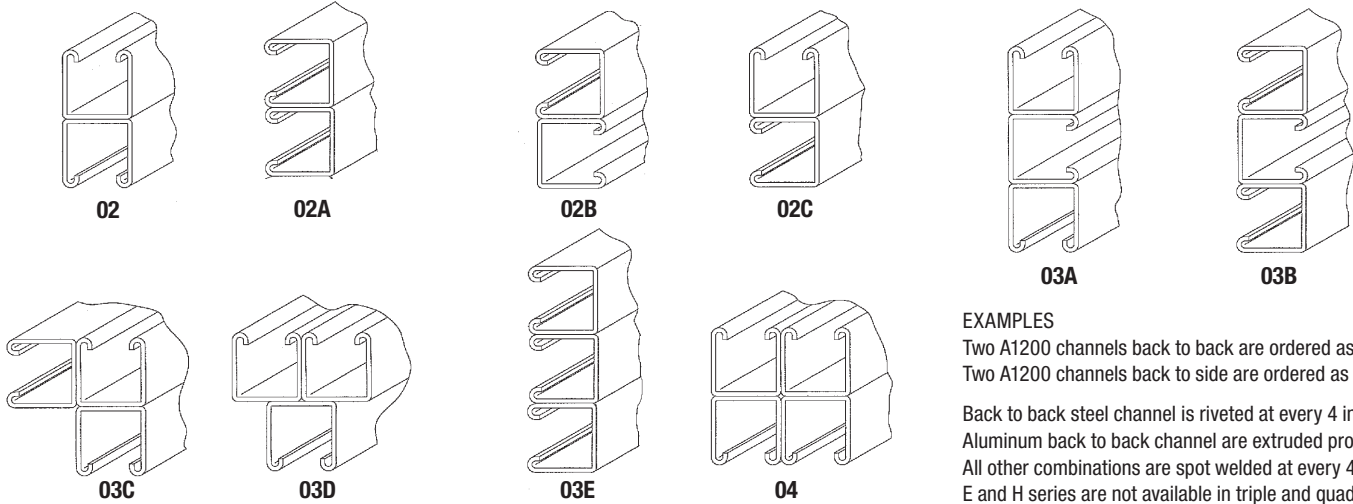

#### EXAMPLES

Two A1200 channels back to back are ordered as A1202.  
Two A1200 channels back to side are ordered as A1202C.

Back to back steel channel is riveted at every 4 inches.  
Aluminum back to back channel are extruded profiles.  
All other combinations are spot welded at every 4 inches.  
E and H series are not available in triple and quadruple.

### End Caps and Closure Strips

#### A804 End Cap

#### RAWSEC End Cap for D1200 Channel

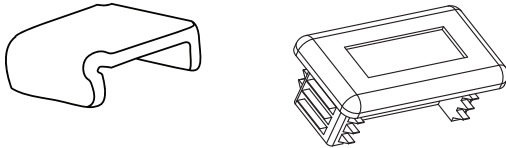

Cat. No.	For Channel	Wt./C lb.
A804EG	A1200	10
	A1400 AR1600	10
B804EG	B1400 BR1600	5
C804EG	C1200	8
E804EG	E1200	15
H804	H1400	20
RAWSEC	D1200	5 g (0.18 oz)

### Safety End Cap

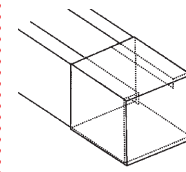

1-5/8 in. x 1-5/8 in. White Plastisol

Cat. No.	For Channel	Wt./C lb.
A804NEOPWH	A1200 AR1600	1.75
	A1400	
B804NEOPWH	B1200 BR1600	5
H804NEOPWH	H1200	2

### A243-1EGC End Cap

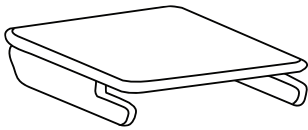

For A1200 Channel  
Wt./C 16 lb.

### A208

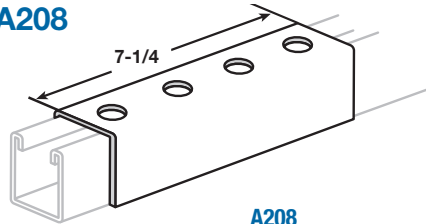

A208HDGC  
A208EG

Does not include  
stud nut or bolts.

A208  
A208SS6C

Pour profilés  
des séries A et AR.  
Poids/100 : 275 lb

### A213 Inside Joiner

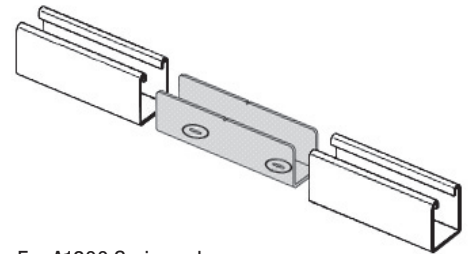

For A1200 Series only.  
Available only in GoldGalv® finish.

### Pre-Galvanized Steel Closure Strip

AB844PGC  
AB844PGCWH  
White Epoxy Powder Coated

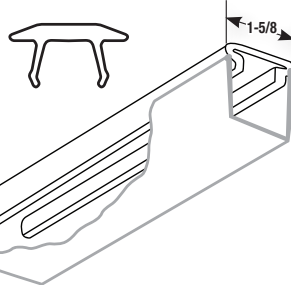

- When used as a raceway, channel is normally installed with the slot up. After wiring has been completed the closure strip is installed.
- For all channels.
- Standard length: 10 ft.

### Plastic Closure Strip

AB844PC Color : Gold  
AB844PCGY Color : Grey



### Stainless Steel Closure Strip

AB844SS6CS (Strapping not included)

