



Introduction

Color-Keyed® Special Lugs for Special Problems — Angled, Shaped and Flared the Way You Need Them

Thomas & Betts can solve your difficult wire bending and terminating problems in confined power distribution panels, switchgear and motor control enclosures.

We have the design and production capability to deliver exactly the type lug you need, shaped the way you need.

- Straight, 45° and 90° angle
- Stacking or non-stacking
- Narrow-tongue or standard
- Tin, silver and nickel plating available

Thomas & Betts offers an extensive line of copper Color-Keyed® lugs for #8 AWG through 1000 kcmil flex and code cables. The lug tongues are modified in several different configurations to meet your exact needs: 45° and 90° bend angles, narrow-tongues to fit into circuit breakers, offset tongues to stack two cables and special stud hole drilling. These special configurations let you:

1. Run cable directly to the bus bar with no bending
2. Terminate into very narrow spaces
3. Utilize minimal bus bar space

The specially designed lugs help you “clean up” your cabling in crowded enclosures.

The pictures show some examples of how and where the lugs can be used.



Customized Color-Keyed® Connectors for Copper Cables

- Standard and special tongue angles, stacking and non-stacking, bolt holes sizes and centers, protective platings.
- Specially modified one and two hole copper Color-Keyed® compression lugs, Series 54100, 54200, 54850BE and 54930BE for flex and code copper stranded cables. Material: high-conductivity wrought copper.
- Minimum order quantity: Standard package quantity by cable size. Consult your Regional Sales Office for price and delivery. All customized lugs are made to order and cannot be cancelled.



Introduction

Order Form (to be scanned or photocopied)

Catalogue No. _____ Qty. _____

Design Controls and Requirements

All "MADE-UP" catalogue numbers start with a standard or basic catalogue number and are followed by the customer-required extra features: Tongue shape, bolt hole size, distance between bolt holes, stacking, plating and inspection hole (peep hole). A code letter or a number has been assigned to each extra feature. See CODE CABLE TABLE below.

- Notes: 1) Lack of any of the extra features on the "MADE-UP" catalogue number means that the standard Cat. No. features are prevalent.
 2) If either bolt hole size or distance between bolt holes needs to be changed from standard Cat. No., both code numbers will appear on the "MADE-UP" Cat. No. (see example below).

Cat. No. 54212UB0416BSP

54212	UB	04	16	B
2 hole 4/0 Cu lug basic cat. no.	90° bend	1/4 in. bolt hole	1 in. hole spacing	bottom stack

Code Cable Table

Tongue Shape		Bolt Holes Size .020		Code	Bolt Hole Centers		Stacking		Finish (Plating)		Inspection Hole (Long Barrel)		Inspection Hole (Short Barrel)	
Type	Code				Center to Center (in.)	Code	Type	Code	Type 1	Code	I.D.	Code	I.D.	Code
45°	UF	#8	0.173	02	1/2	08	Top	T**	Silver	SP	Peep Hole	PH	Blind End	BE
90°	UB	#10	0.204	03	5/8	10	Bottom	B	Lead	LP				
Blank	BT	1/4	0.281	04	3/4	12			Nickel	NP	150°			
(No Bolt Hole)		5/16	0.344	05	7/8	14			Plain Finish	PF				
		3/8	0.406	06	1	16			No Marking	NM				
		1/2	0.531	08	1-1/8	18								
		5/8	0.656	10	1-1/4	20								
		3/4	0.812	12	1-3/8	22								
		1/8	0.937	14	1-1/2	24								
		1	1.062	16	1-5/8	26								
					1-3/4	28								
					*1-7/8	30								
					*2	32								

* These bolt centers are not available for bolt holes larger than 13/16 in.
 ** Not required for 45° & 90° Top Stacking.

Cable	Code	<input type="checkbox"/>
	Weld	<input type="checkbox"/>
<input type="checkbox"/> #8	<input type="checkbox"/> #6	<input type="checkbox"/> #4
<input type="checkbox"/> #2	<input type="checkbox"/> #1	<input type="checkbox"/> 1/0
<input type="checkbox"/> 2/0	<input type="checkbox"/> 3/0	<input type="checkbox"/> 4/0
<input type="checkbox"/> 250 kcmil & up (Code cable Only)		

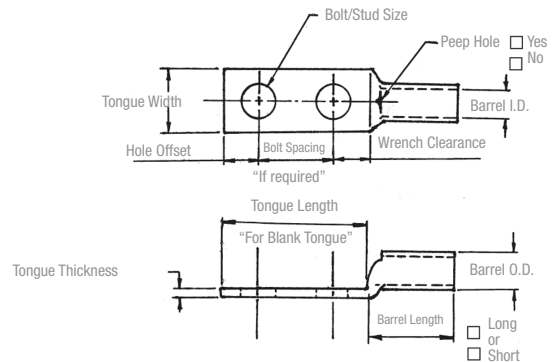

Introduction

Tongue Specifications — See Chart “A” for Dimensions

Stud Sizes		
<input type="checkbox"/> #8	<input type="checkbox"/> #10	<input type="checkbox"/> 1/4 in.
<input type="checkbox"/> 5/16 in.	<input type="checkbox"/> 3/8 in.	<input type="checkbox"/> 1/2 in.
<input type="checkbox"/> 5/8 in.	<input type="checkbox"/> 3/4 in.	<input type="checkbox"/> 7/8 in.
<input type="checkbox"/> 1 in.		

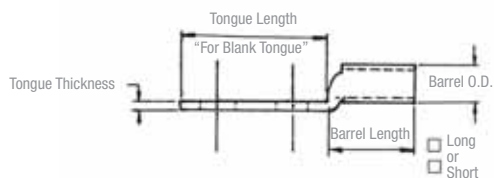
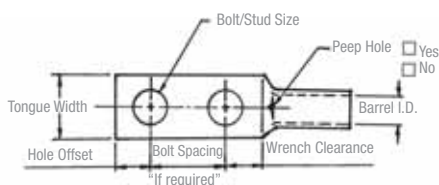

Chart A

Nominal Bolt Hole	Hole Offset	Min. Wrench Clearance	Tongue Width Cable Size										
			#8 Code #8 Weld	#6 Code #6 Weld	#4 Code	#2 Code #4 Weld	#1 Code #2 Weld	1/0 Code #1 Weld	2/0 Code 1/0 Weld	3/0 Code 2/0 Weld	4/0 Code 3/0 Weld	250 Code	
#8	0.173	0.200	0.240	0.406	0.437	0.562	0.593	0.672	0.750	0.825	0.937	1.030	1.125
#10	0.204	0.218	0.250										
1/4	0.281	0.250	0.312	0.469	0.500								
5/16	0.344	0.375	0.406	0.562	0.562	0.594	0.675	0.750	0.750	0.937	1.030	1.125	
3/8	0.406	0.375	0.440	0.578	0.578								
1/2	0.531	0.500	0.562	-	-	-	-	-	-	-	-	-	
5/8	0.656	0.812	0.875										
3/4	0.812	0.750	0.770	-	-	-	-	-	-	-	-	-	
*7/8	0.937	0.875	0.890										
*1	1.062	0.937	1.000	-	-	-	-	-	-	-	-	-	

* These bolt holes are available in one hole lug only. Dimensions are in inches.

Chart B

Cable Size	Tongue Thickness	Straight Lug Barrel Length		Barrel		Dim. "X" Stacked Lugs			Dim. "Y"		Dim. "H"	
		Short	Long	O.D.	I.D.	Straight	45°	90°	Short	Long	Short	Long
#8	0.080	0.635	0.935	0.260	0.180	0.158	0.478	0.394	0.595	0.808	0.779	1.079
#6	0.081	0.675	0.975	0.296	0.215	0.134	0.544	0.432	0.587	0.799	0.767	10.67
#4	0.099	0.685	0.985	0.365	0.266	0.175	0.622	0.502	0.637	0.849	0.838	1.138
#2	0.108	0.815	1.115	0.410	0.302	0.216	0.649	0.535	0.711	0.923	0.958	1.258
#1	0.106	0.825	1.275	0.467	0.361	0.212	0.731	0.592	0.710	1.028	0.956	1.406
1/0	0.125	0.975	1.325	0.520	0.396	0.250	0.789	0.646	0.794	1.042	1.075	1.425
2/0	0.125	0.965	1.315	0.571	0.446	0.250	0.859	0.696	0.829	1.077	1.125	1.475
3/0	0.125	1.085	1.435	0.632	0.507	0.250	0.946	0.757	0.900	1.148	1.225	1.575
4/0	0.137	1.255	1.705	0.701	0.564	0.274	1.031	0.826	1.015	1.333	1.387	1.837
250	0.137	1.375	1.925	0.766	0.629	0.274	1.123	0.891	1.085	1.474	1.487	2.037
300	0.153	1.900	2.675	0.850	0.660	0.459	1.226	0.975	1.180	1.726	1.924	2.679
350	0.177	2.090	2.896	0.926	0.720	0.531	1.333	1.103	1.267	1.830	2.096	2.896
400	0.173	2.460	2.980	0.960	0.757	0.519	1.370	1.085	1.551	1.913	2.484	2.984
500	0.218	2.670	3.610	1.100	0.852	0.654	1.514	1.225	1.629	2.266	2.669	3.619
600	0.244	2.900	3.490	1.200	0.926	0.732	1.630	1.325	1.762	2.147	2.897	3.497
700	0.228	2.784	-	1.255	0.997	0.684	1.662	1.375	1.780	-	3.011	-
750	0.270	3.050	3.925	1.330	1.030	0.810	1.745	1.455	1.827	2.434	3.050	3.925
800	0.266	3.213	-	1.375	1.079	0.800	1.728	1.625	1.952	2.787	3.213	4.554
900	0.313	3.450	4.550	1.500	1.145	0.940	1.900	1.650	2.065	-	1.387	-
1,000	0.297	3.356	4.500	1.550	1.203	0.890	2.070	1.675	2.031	2.787	1.487	4.506

Stacking lugs are available for one bolt only. Consult your Regional Sales Office for details. Straight: 700 kcmil & up; 45°: 400 kcmil & up; 90°: 500 kcmil & up. Dimensions are in inches.

Introduction

Tongue Specifications — See Chart “A” for Dimensions

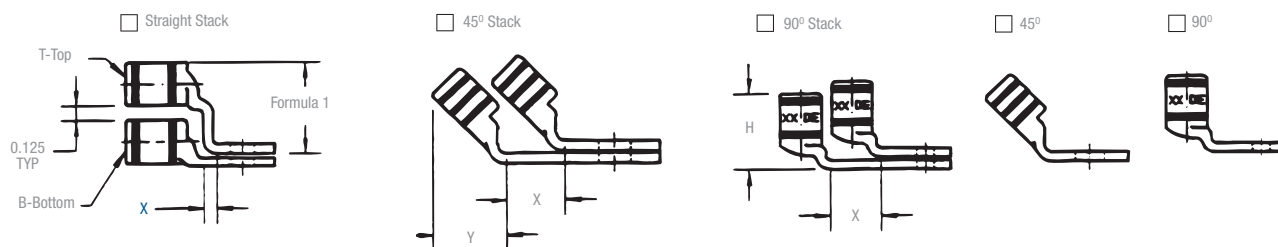

Formula 1 = (0.125 + 2 (OD) + 0.037 – Tongue Thickness)

Chart C

Tongue Width 0.030 / Code Cable Size											
Bolt Hole Size	300 kcmil 4/0 Weld	350 kcmil	400 kcmil	500 kcmil 400 Weld	600 kcmil 500 Weld	1325/24	700 kcmil	750 kcmil	800 kcmil	900 kcmil	1000 kcmil
#8	-	-	-	-	-	-	-	-	-	-	-
#10	-	-	-	-	-	-	-	-	-	-	-
1/4	1.250	1.355	1.410	1.605	1.745	1.805	1.840	1.935	2.010	2.180	2.265
5/16											
3/8											
1/2											
5/8											
3/4	-	-	-	-	-	-	-	-	-	-	
*7/8	-	-	-	-	-	-	-	-	-	-	-
*1	-	-	-	-	-	-	-	-	-	-	-

* These bolt holes are available in one hole lug only. Dimensions are in inches.

Compression Connectors for Copper Conductors



Cast Copper One-Hole Lugs Heavy-Duty Certified to 600 V and Recommended up to 35 kV‡

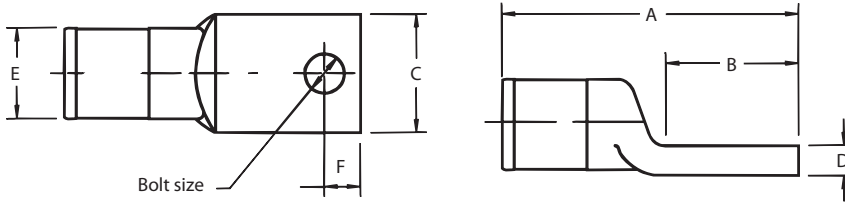

Material: High-Conductivity Wrought Copper
Finish: Electro-Tin Plated



Cat. No.	Code Cable Size	Dimensions in. (mm)					Bolt Size (in.)	Die Code
		A	B	C	D	F		
53104	8	1.43 (36.3)	0.75 (19.1)	0.50 (12.7)	0.12 (3.0)	0.28 (7.1)	#10	29
53105	6	1.43 (36.3)	0.75 (19.1)	0.50 (12.7)	0.12 (3.0)	0.28 (7.1)	1/4	
53106	4	1.43 (36.3)	0.75 (19.1)	0.50 (12.7)	0.12 (3.0)	0.28 (7.1)		
53107	2	2.00 (50.8)	1.00 (25.4)	0.75 (19.1)	0.25 (6.4)	0.43 (10.9)		
53108	1	2.00 (50.8)	1.00 (25.4)	0.75 (19.1)	0.25 (6.4)	0.43 (10.9)		45
53109	1/0	2.00 (50.8)	1.00 (25.4)	0.75 (19.1)	0.25 (6.4)	0.43 (10.9)	3/8	54
53161*	325/24	2.18 (55.4)	0.75 (19.1)	0.81 (20.6)	0.21 (5.3)	0.43 (10.9)		
53110	2/0	2.63 (66.8)	1.25 (31.8)	1.00 (25.4)	0.28 (7.1)	0.53 (13.5)		
53111	3/0	2.63 (66.8)	1.25 (31.8)	1.00 (25.4)	0.28 (7.1)	0.53 (13.5)		66
53112	4/0	2.63 (66.8)	1.25 (31.8)	1.00 (25.4)	0.28 (7.1)	0.53 (13.5)	1/2	76
53165*	650/24	3.06 (91.4)	1.38 (35.1)	1.18 (30.0)	0.31 (7.9)	0.75 (19.1)		
53113	250 kcmil	3.06 (91.4)	1.50 (38.1)	1.18 (30.0)	0.31 (7.9)	0.75 (19.1)		
53114	300 kcmil	3.06 (91.4)	1.50 (38.1)	1.18 (30.0)	0.31 (7.9)	0.75 (19.1)		
53115	350 kcmil	3.81 (96.8)	2.00 (50.8)	1.38 (35.1)	0.38 (9.7)	0.81 (20.6)		
53116	400 kcmil	3.81 (96.8)	2.00 (50.8)	1.38 (35.1)	0.38 (9.7)	0.81 (20.6)		
53118	500 kcmil	3.81 (96.8)	2.00 (50.8)	1.38 (35.1)	0.38 (9.7)	0.81 (20.6)		
53168*	1100/24	3.81 (96.8)	1.63 (41.4)	1.63 (41.4)	0.40 (10.2)	0.88 (22.4)		107
53169*	1325/24	3.81 (96.8)	1.63 (41.4)	1.63 (41.4)	0.40 (10.2)	0.88 (22.4)		112
53123	750 kcmil	4.18 (106.2)	2.12 (53.8)	1.63 (41.4)	0.43 (10.9)	1.00 (25.4)		
53173*	2750/24	5.06 (142.2)	1.88 (47.8)	2.12 (53.8)	0.56 (14.2)	1.18 (30.0)	150	

‡ For installations from 16 kV up to 35 kV, consult shielded cable manufacturers for stress relief and insulation requirements.

Applicable tools: 12, 14, 15 and 40-Tons (see tool section E4–E62).

* Not UL Listed and CSA non applicable.

Die Selector Chart: pp. E35–E50