

Hardware and Threaded Components



E145 Hex Nut

CAT. NO.	SIZES (IN.)	WT. LBS./C
E145 1/4	1/4-20	1.2
E145 5/16	5/16-18	2.0
E145 3/8	3/8-16	3.2
E145 1/2	1/2-13	5.0
E145 3/8	3/8-11	9.0

Standard finish: Galv-Krom® unless otherwise specified.



E146 Square Nut

CAT. NO.	SIZES (IN.)	WT. LBS./C
E146 1/4	1/4-20	1.00
E146 5/16	5/16-18	2.40
E146 3/8	3/8-16	2.37
E146 1/2	1/2-13	6.00
E146 5/8	5/8-11	11.00

Standard finish: Galv-Krom® unless otherwise specified.

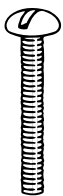

54, E149 Round Head Machine Screw — Less Nut

CAT. NO.	SIZES (IN.)	WT. LBS./C
54 571P	1/4-20 x 1/2	1.00
54-572-P	1/4-20 x 3/4	1.25
54-574	1/4-20 x 1 1/4	1.76
54-576	1/4-20 x 2	2.54
E149 3/8 1 1/4	3/8-16 x 3/4	3.45

Standard finish: Galv-Krom® unless otherwise specified.



E147 Flat Steel Washer

CAT. NO.	SIZES (IN.)	WT. LBS./C
E147 1/4	1/4	.67
E147 5/16	5/16	1.20
E147 3/8	3/8	2.00
E147 1/2	1/2	3.85
E147 5/8	5/8	7.70
E147 3/4	3/4	9.00

Standard finish: Galv-Krom® unless otherwise specified.



E148 Lock Washer

CAT. NO.	SIZES (IN.)	WT. LBS./C
E148 1/4	1/4	.259
E148 5/16	5/16	.550
E148 3/8	3/8	.630
E148 1/2	1/2	1.436
E148 5/8	5/8	2.587
E148 3/4	3/4	4.293

Standard finish: Galv-Krom® unless otherwise specified.

AB241 Square Washer

CAT. NO.	DIMENSIONS (IN.)		WT. LBS./C
	SIZE	THICKNESS	
AB241 1/4	1/4	1/8	8.10
AB241 5/16	5/16	1/8	8.00
AB241 3/8	3/8	3/16	11.50
AB241 1/2	1/2	1/4	14.36
AB241 5/8	5/8	1/4	13.50
AB241 3/4	3/4	1/4	12.50
AB241 7/8	7/8	1/4	13.00

Standard finish: Galv-Krom® unless otherwise specified.

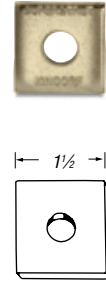

Located Square Washers

CAT. NO.	BOLT SIZE (IN.)	STD. CTN.
AB-241L-1/4	1/4	100
AB-241L-5/16	5/16	100
AB-241L-3/8	3/8	100
AB-241L-1/2	1/2	100
AB-241L-5/8	5/8	100

GoldGalv® is standard finish.

Add "EG" suffix for SilverGalv®.

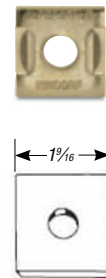

H-550 Swivel Beam Clamp

One-piece malleable-iron casting. Attaches to beam flanges up to 3/4" thickness.

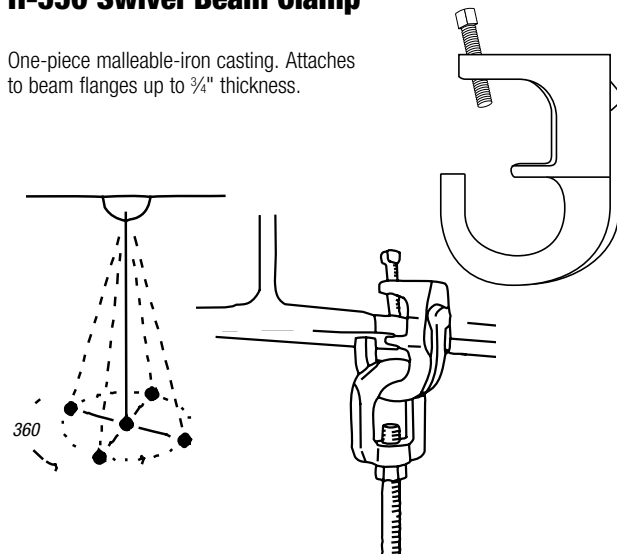

CAT. NO.	DESCRIPTION	WT. LBS./C
H-550	Max. load rating 500 lbs. with a safety factor of 3.	33

Galv-Krom® finish.

Overview

Finishes (continued)

GoldGalv®

The standard GoldGalv® finish is made up of a multi-step electrogalvanizing and zinc trivalent chromium process. The trivalent chromium finish is applied over the zinc, producing a chemically bonded non-porous barrier for protection from moisture and air. The .5 mil electro-plated zinc and gold trivalent chromium finish provides all of the features and protection of hexavalent chromium without the use of the chemical.

SilverGalv® (Suffix EG)

Often referred to as “zinc plated” or “electroplated zinc,” the steel and .5 mils of zinc are bonded by an electrolysis process. This is the identical process used in the Superstrut Goldgalv® finish without the numerous benefits of the gold-colored trivalent chromium conversion coat (see GoldGalv® finish for more information). Electrogalvanizing is most commonly applied to small fittings, hardware and threaded products.

Green or White Urethane Powder Coated (Suffix GR or WH)

Urethane powder resins are applied electrostatically to the steel after fabrication. Once the material is completely covered with the powder-form urethane, it proceeds through a 400° baking process for ten minutes, creating a chemical bond. This results in a minimum of 1.5 mil thickness of urethane coating, providing excellent resistance to chipping or peeling.

Pregalvanized (Suffix PG)

A zinc coating is applied by hot-dipping the steel coil at the mill prior to fabrication. Once the material is worked by roll-forming, cutting or punching, minimal protection is provided for raw edges. This weakness is typical with precoated material and affects the channel section around holes, extreme ends and the edges of the “U” shape lips. Superstrut pregalvanized material is in conformance with ASTM A-525/G-90 specification standards, representing 0.90 ounces of zinc per square foot of steel. This finish is often referred to as “hot-dipped mill galvanized” or “mill galvanized.”

Hot-Dipped Galvanized (Suffix HDG)

The material is zinc coated after fabrication, providing total product protection on all surfaces. The fabricated channel or fitting is suspended and then dipped into tanks of hot zinc for a prolonged period, creating a coherent bond. The result is superior corrosion resistance as compared to pregalvanized material. Hot-dipped galvanizing is not recommended for threaded products, because the thickness of the zinc coating will often disrupt the threads. Superstrut hot-dipped galvanized is in conformance with ASTM Specifications A-123 (formerly A-386) and A-153. Superstrut channels maintain a minimum 1.5 ounces of zinc per square foot of steel or 2.5 mils (ASTM A-123, Thickness Grade 65). This finish is also referred to as “hot-dipped galvanized after fabrication.”

PVC Coated (Suffix PVC)

A polyvinyl chloride (PVC) plastic coating is fused to the channel, fitting or accessory after fabrication by immersing the part in fluidized PVC tanks. The fused-melt mixed powder PVC coating thickness is 15 mils (.015”) plus or minus five mils. PVC material is a thermoplastic and will soften in high temperature. An inherent weakness with PVC coatings occurs when field alterations are applied, such as cutting or drilling. These acts disrupt the sealed PVC product and warrant field touch-up. Thomas & Betts cannot be held responsible for field-altered PVC coated products.

Copper Plated (“T” inserted as the second digit of the part number; Example: CTL-710-2)

Plain steel proceeds through a series of rinse tanks to clean the material surface. Once cleaned, the fabricated part is etched by dipping into an acid pickle bath to prepare the surface for adhesion. Copper is electrically applied by submerging in a copper bath. To seal the finish, the product continues to a sealer tank and is then dried by forced hot air.

Black (Suffix B)

A black finish is raw steel with only a light oil finish as supplied by the steel manufacturer. There is no protection against red rust.

Stainless Steel (Suffix SS)

Superstrut channel is supplied in type 304 stainless steel when required. Type 316 stainless steel may be available upon request.

Aluminum (Suffix AL)

Superstrut channel and hardware are available in aluminum.

Warning: Load tables, charts and design criteria provided in this catalog are intended as guides only. Selection of proper product, installation intervals, erection and placement are the responsibility of the user.

Superstrut® products are intended to be used for the support and bracing of fixtures, cable, pipe and conduit. Improper use or installation may result in injury to persons or damage of property.

Material and finish specifications are subject to change without notice.



Threaded Products and Hardware

A-100 Regular Spring Nut

Sizes: 1/4", 5/16", 3/8", 1/2", 5/8", 3/4" & 1"

Nut is square over 1/2" size.
For all "A" and "C" series channel and inserts.



E-145 Standard Hex Nut

Sizes: 1/4", 3/8", 1/2", 5/8", 3/4", 7/8" & 1"

GoldGalv® Finish.



E-151-D Wood Screw Drive

Size A: 1/4"

Size B: 2"

Max. Rec. Load: 100 lbs.

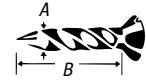

AB-100 Springless Nut

Sizes: 1/4", 5/16", 3/8", 1/2", 5/8" & 3/4"

Nut is square over 1/2" size.
For use with all channels.
Silver Electroplated Finish.

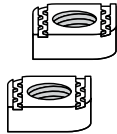

E-146 Standard Square Nut

Sizes: 1/4", 5/16", 3/8", 1/2" & 5/8"

GoldGalv® Finish.



ES-142 Seismic Stiffener Nut

Size: ES-142-1/2 x 1 1/2"

Bolt Dia.: 1/2"

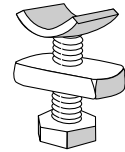

AC-100 Springless Nut

Sizes: 1/4", 3/8", 1/2", 5/8" & 3/4"

Nut is square over 1/2" size.
For all "A", "C", "E" and "H" series channel and inserts.

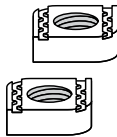

E-147 Flat Steel Washer

Sizes: 1/4", 5/16", 3/8", 1/2", 5/8", 3/4" & 7/8"

GoldGalv® Finish.



ES-145 Swivel Nut and Jam Nut Combinations

Sizes: 3/8" & 1/2"

GoldGalv® Finish.

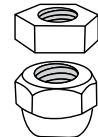

B-100 Short Spring Nut

Sizes: 1/4", 5/16", 3/8" & 1/2"

Nut is square over 1/2" size.
For all "B" series channel and inserts.

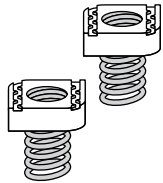

E-148 Lock Washer

Sizes: 1/4", 3/8", 1/2" & 5/8"

GoldGalv® Finish.



H-100 Long Spring Nut

Sizes: 3/8", 1/2" & 5/8"

Nut is square over 1/2" size.
For all "E" and "H" series channel and inserts.

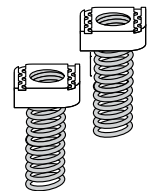

CM-100 Nylon Cone Nut

Sizes: 1/4", 3/8" & 1/2"

For all 1 5/8" channel.

*Will not fit "B" series channel.

GoldGalv® Finish



E-149 Slotted Hex Indented Head Machine Screw

Sizes: 1/4" x 3/4", 1/4" x 1", 5/16" x 1 1/4" & 3/8" x 1 1/4"

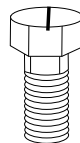

UC-100 Universal Nylon Cone Nut

Sizes: 1/4", 3/8" & 1/2"

For all 1 5/8" & 1 1/2" channels.
May be used with ALL strut depths. Can be used for CM-100, A-100, B-100 & AB-100 Series.

GoldGalv® Finish.



E-142 Hex Head Cap Screw

Sizes: 1/4" x 1", 1/4" x 1 1/2", 3/8" x 1", 3/8" x 1 1/2", 1/2" x 1 5/16" & 1/2" x 1 1/2"

See price sheet for additional sizes.



E-150-S Lag Bolt Screw

Size: 3/8" & 1/2"

Drill Size: 1/4" & 1 1/32"

