

Pipe Straps, Conduit Clamps and Hangers

CL-710 — Light-Duty Clevis Hanger

Designed to support non-insulated, stationary lines from above, allowing for approximately 1" to 1½" of vertical adjustment after the pipe is in place. The lower nut (not furnished) adjusts the pipe line to the proper elevation, the top nut (not furnished) prevents loosening due to vibration and must be tightened securely to assure proper hanger performance.

Specifications

- Material: Carbon Steel
- Compliance: Federal Specification A-A-1192A Type 1, MSS-SP-69 Type 1
- Finish: Standard Finish – GoldGalv®, Black (add suffix “-B”), Electro-Galvanized (add suffix “-EG”)
- Ordering: Specify catalog number, finish and pipe size

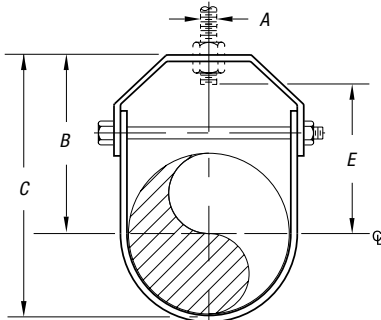

CL-710

CTL-710 — Copper Clevis Hanger

Designed to support non-insulated, stationary copper tubing lines from above, allowing for approximately 1" to 1½" of vertical adjustment after the tubing is in place. The lower nut (not furnished) adjusts the pipe line to the proper elevation. The top nut (not furnished) prevents loosening due to vibration and must be tightened securely to assure proper hanger performance.

Specifications

- Material: Carbon Steel
- Compliance: Federal Specification A-A-1192A Type 1, MSS-SP-69 Type 1 and BSPSS-BS3974. Rated Loads are for up to 650° F (343° C)
- Finish: Copper
- Ordering: Specify tubing size and catalog number

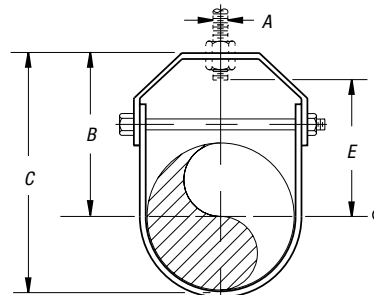

CTL-710

CAT. NO.	PIPE SIZE (IN.)	MAX. LOAD (LBS.)	A (IN.)	B (IN.)	C (IN.)	E (IN.)	WT. EACH (LBS.)
CL710 1/2	½	150	¾	1 ¼	2 ½	¾	.27
CL-710-3/4	¾	250	¾	2 ½	2 ½	1 ½	.29
CL-710-1	1	250	¾	2 ½	3 ¾	1 ¾	.33
CL-710-1-1/4	1 ¼	250	¾	2 ½	3 ¾	2 ½	.36
CL-710-1-1/2	1 ½	250	¾	3	4	2 ¼	.42
CL-710-2	2	250	¾	3 ½	4 ¾	2 ¾	.52
CL-710-2-1/2	2 ½	350	½	4	5 ½	2 ½	.81
CL-710-3	3	350	½	4 ¼	6 ½	3 ¼	.90
CL-710-3-1/2	3 ½	350	½	4 ¾	6 ½	3 ¾	.99
CL-710-4	4	400	¾	5 ½	7 ¾	4 ¾	1.40

Standard Finish – GoldGalv®, unless otherwise stated.

CAT. NO.	PIPE SIZE (IN.)	MAX. LOAD (LBS.)	A (IN.)	B (IN.)	C (IN.)	ROD TAKE OUT E (IN.)	WT. EACH (LBS.)
CTL710 1/2	½	150	¾	2 ¼	3 ¼	2 ¼	.16
CTL-710-3/4	¾	250	¾	2 ¼	3	1 ¾	.16
CTL-710-1	1	250	¾	2 ¼	3 ¼	1 ¾	.19
CTL-710-1-1/4	1 ¼	250	¾	3 ¼	3 ¾	2 ¾	.22
CTL-710-1-1/2	1 ½	250	¾	3 ¾	4 ¼	2 ¾	.29
CTL-710-2	2	250	¾	3 ¾	4 ¾	2 ¾	.32
CTL-710-2-1/2	2 ½	350	½	3 ¾	4 ¾	2 ¾	.72
CTL-710-3	3	350	½	3 ¾	5 ¾	2 ¾	.82
CTL-710-3-1/2	3 ½	350	½	4 ¼	5 ¾	3 ¾	.91
CTL-710-4	4	350	½	4 ½	6 ¼	3 ¾	1.07
CTL-710-5	5	900	¾	5	7 ¼	3 ¾	1.76
CTL-710-6	6	900	¾	5 ¾	8 ¾	4 ¾	1.92

Standard Finish – GoldGalv®, unless otherwise stated.