

MOGUL LAMPHOLDERS

Two-Piece • Mogul-to-Mogul Extension
E39 Base



HID • INCANDESCENT

Porcelain Two-Piece

Porcelain body white glazed. Copper alloy nickel-plated screw shell and center contact. Screw terminals. Elongated mounting holes for #8-32 screws on 1 1/2" centers. 3/4" dia. cord hold in cap.

Standard pack: bulk

Cat. No. 8765

- 1500W-600V • UL Listed E-13402 • NOM Certified 057



8765

Mogul-to-Mogul Extension

Copper alloy nickel-plated screw shell. Extends mogul lamp 2 3/8".

Standard pack: bulk

Cat. No. 8647-100

- 1500W-600V • 4 KV Pulse Rated • UL Listed E-13396 • CSA Certified LR-1863

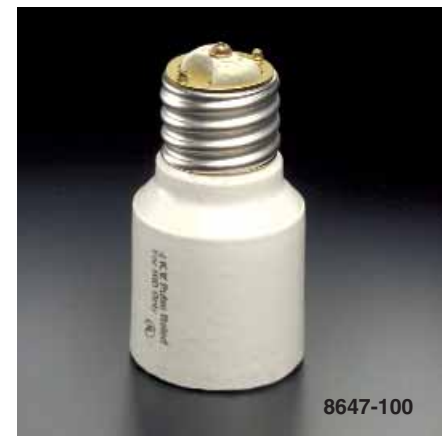

8647-100

SECTION D

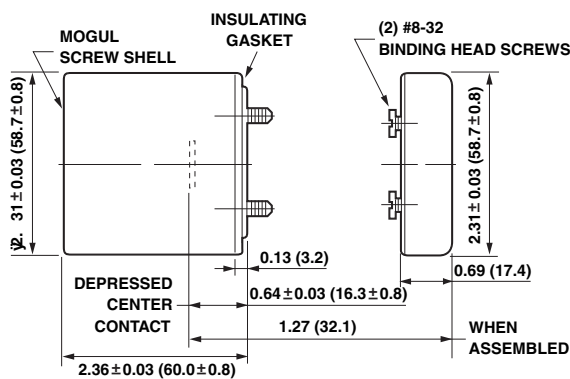

Cat. No. 8765

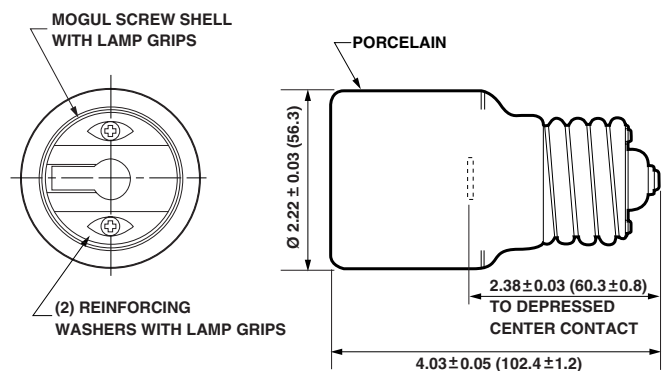

Cat. No. 8647-100