

MEDIUM BI-PIN TURN-TYPE LAMPHOLDERS

Tall Profile • G13 Base



LINEAR FLUORESCENT



13354

Turn-Type Lampholders for T-8 and T-12 Lamps

Tall profile. Molded, white thermosetting urea. Knife-edge contacts. Quickwire pressure terminals accept stranded No. 18 gauge, twisted and overtinned, or No. 18 solid or solder-dipped leads, stripped 3/8". Multiple terminal slots permit double connections at each contact. Recessed wire wells completely enclose conductor, insulating against shorts. Screws assembled or furnished bulk are #6-32 x 3/8".

Cat. Nos. 13354 & 13355

Lampholders with Internal Shunt Connection

Specially designed for use with electronic ballasts.

Provides easier fixture assembly by eliminating need for jumper-wire. Large "S" identifies shunted version.

Cat. Nos. 23354 & 23355

- 660W-600V
- UL Listed E-5833
- CSA Certified LR-5863
- NOM Certified 057

Cat. No.	A Dim. Thickness	Side Groove Mounting	With Captive Nut Assembled	Internal Shunt
13354	3/8 (9.53)	For #20 ga. panel	-	-
13354-00N	3/8 (9.53)	For #20 ga. panel	X	-
23354	3/8 (9.53)	For #20 ga. panel	-	X
13355	11/32 (8.73)	For #20 ga. panel	-	-
13355-00N	11/32 (8.73)	For #20 ga. panel	X	-
23355	11/32 (8.73)	For #20 ga. panel	-	X

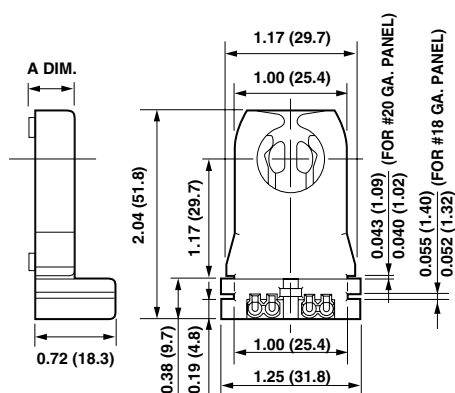

Cat. No. 13354

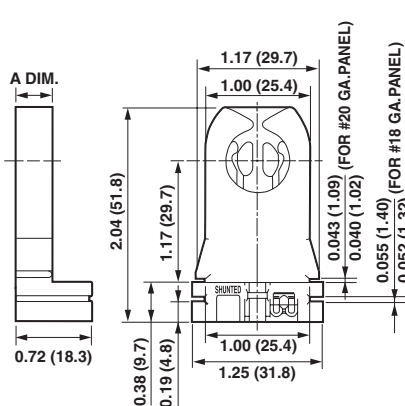

Cat. No. 23354

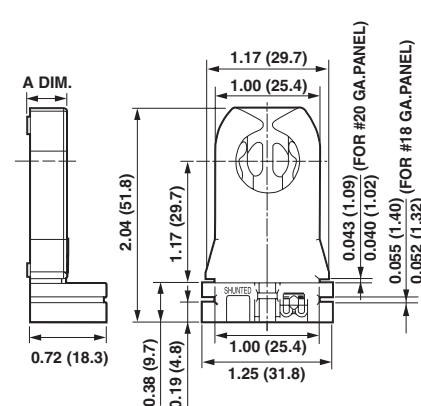

Cat. No. 23355