

# MEDIUM BI-PIN WITH INTERNAL SHUNT TURN-TYPE

Low Profile • G13 Base



LINEAR FLUORESCENT



23351

## Lampholder with Internal Shunt Connection for T-8 and T-12 Lamps

Specially designed for use with electronic ballasts.

Provides easier fixture assembly by eliminating need for jumper-wire.

Turn-type, low profile, medium bi-pin lampholder with internal shunt connection. Knife-edge contacts. Body is molded, white thermosetting urea. Quickwire pressure terminals accept stranded No. 18 gauge twisted and overtinned, or No. 18 gauge solid or solder-dipped leads, stripped 3/8". Recessed wire well completely encloses conductor, insulating against shorts. The recessed wire well on one side of the lampholder is blocked off and labeled "SHUNTED," and the back cover is stamped "S" to help prevent improper applications.

**Cat. No. 23351:** Medium Bi-Pin Turn-Type Fluorescent Lampholder for T-8 and T-12 Lamps, with internal shunt connection for use with electronic ballasts.

**Cat. No. 23351-REJ:** With rejection post on body, for T-8 lamps only.

**Cat. No. 23351-00N:** Captive nut and screw.

**Cat. No. 23353:** With two side and two base slots for 18 ga. panels.

- 660W-600V
- UL Listed E-5833
- CSA Certified LR-1863

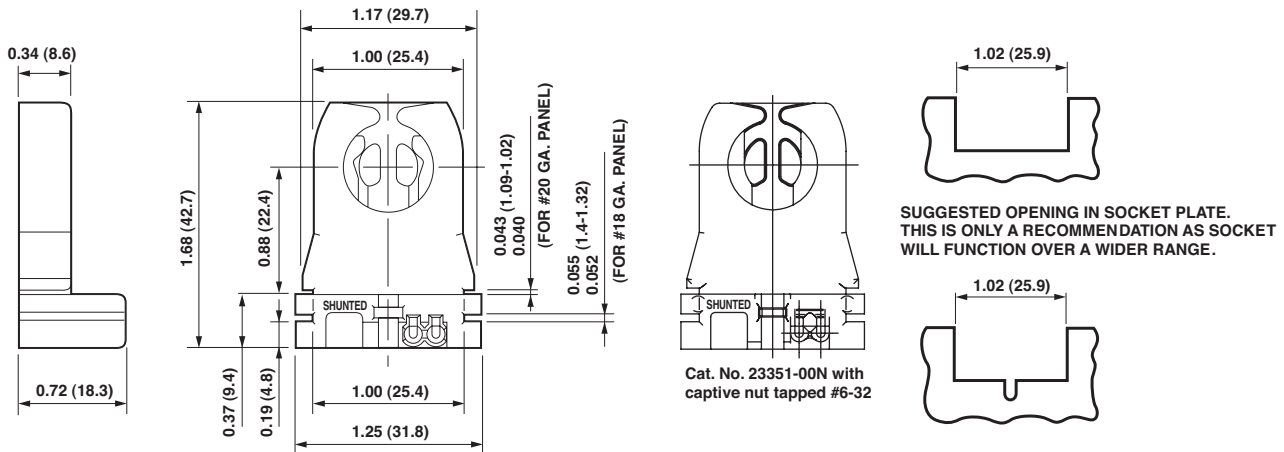

Cat. No. 23351

