

TECHNICAL INFORMATION

SOLVENT CEMENTING

After cutting Scepter Rigid PVC Conduit, remove all sharp edges or burrs from the inside of the conduit with a knife. Thoroughly clean the end of the pipe and inside the fitting with a rag or pipe cleaner. Check the pipe and fitting for a dry fit before cementing. Apply a generous amount of IPEX solvent cement to both surfaces; slide together and give a quarter turn to ensure the solvent is spread evenly on the material. Hold together for a few seconds until the joint is made.

Usually the solvent-cemented joint will be strong enough to install immediately. However, in climates with low temperatures or areas with high humidity, extra time may be required before moving the pipe for permanent installation. Solvent-cemented joints appear to “set up” instantly, but will take up to 24 hours to cure properly. After this time, the solvent-cemented joint has completely cured and is waterproof. For extreme cold weather installations, the use of IPEX PVC Primer is recommended. Normal installation temperatures are between 40°F and 110°F, however, high strength joints have been made at temperatures as low as -15°F with quality cements. In these extreme conditions the cement must be kept warm to prevent excessive thickening and gelation in cold weather.

IPEX cements and primers are available in quarter-pint, half-pint, pint, quart and gallon containers. The shelf life of conduit cement and primer is 2 years from the date of manufacture. The date code stamped on the bottom of the can is the date of manufacture, not the expiry date. Always verify that the cement is within this 2 year time frame before using.



BENDING

PVC is a thermoplastic material that, when heated, becomes soft and pliable. As a result, its shape can be altered.

A flameless heat source is recommended to heat the pipe. AN OPEN FLAME SHOULD NOT BE USED. An electric unit or an infra-red propane unit is recommended for heating the pipe.

The necessary temperature for bending Scepter Rigid PVC pipe is 260°F. The pipe must be heated evenly over an area approximately ten times the diameter of the pipe before any attempt at bending is made. Bending the pipe when it has not been thoroughly heated will cause the pipe to “kink.” With proper care and a little practice, the bend will form easily.

Cooling the pipe with cold air or water will cause “spring back.” Allow a few extra degrees of overbending to compensate for this phenomenon. The maximum bending radius shall be six times the internal diameter according to the National Electrical Code.



TECHNICAL INFORMATION EXPANSION FITTINGS

USING EXPANSION JOINTS

It is equally important to know when to install an expansion joint as it is to know how to correctly install the expansion joint. Expansion joints are required when the temperature change is greater than 25°F. Scepter Rigid PVC Conduit has a coefficient of linear expansion of 3.6×10^{-4} in./ft./°F. Generally, a 100 ft. run of PVC conduit will undergo a change in length of 3.6 inches for every 100°F temperature change.

For conduit installed indoors, the range of expansion and contraction can be calculated using the maximum air temperature plus the heat contributed by the conductors inside the conduit and the minimum air temperature expected. Expansion joints are not required indoors unless there are widely varying temperatures such as the attic of a building.

Conduit installed outdoors, exposed to direct sunlight, will be considerably hotter than the air temperature. As a guideline in this case, add 27°F to the temperature change. Expansion joints should be installed to allow for all anticipated temperature changes.

EXPANSION FORMULA

By using the following formula and the chart below, the total expected expansion in a run can be easily determined:

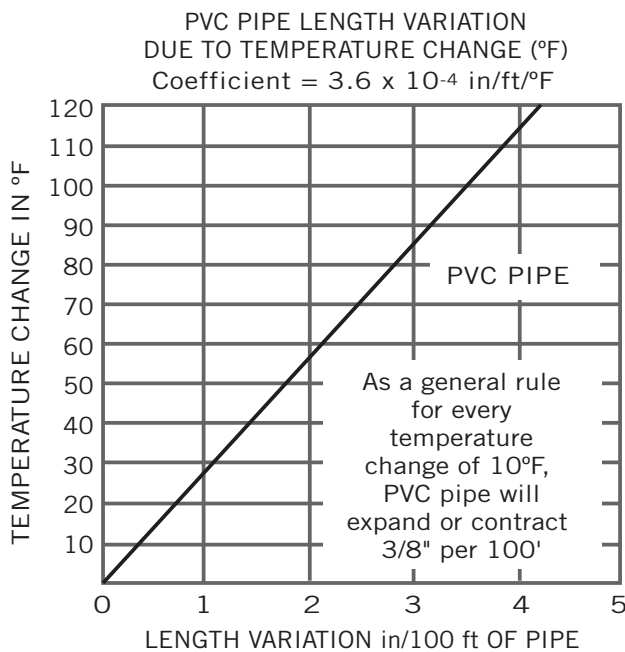

$$\begin{aligned} \text{°F} \quad \text{Total Expansion (in.)} &= \text{length of run (ft.)} \\ &\times \text{temperature change (°F)} \times 0.00036 \end{aligned}$$

TECHNICAL INFORMATION EXPANSION FITTINGS

NUMBER OF EXPANSION JOINTS REQUIRED

Use the following equation to determine the number of expansion joints needed for a Scepter Rigid PVC Conduit installation:

$$\text{Number of joints} = \frac{\text{total expansion (in)}}{E}$$

E = Expansion joint travel length 4" or 8" depending on diameter.

Always round up to the next whole number.

SETTING THE PISTON OPENING

The expansion joint must be installed to allow for expansion and contraction of the conduit run. On a cold day, if an expansion joint is installed completely closed with the piston bottomed, there is no room for expansion when the conduit is warmed. If it is installed open to the maximum on a hot day, the expansion joint will pull apart when cooled.

The correct piston opening for any installation condition can be easily determined using the formula below.

$$\text{Piston setting} = \text{compressed length} + \left(\frac{\text{max. temperature} - \text{installation temperature}}{\text{max. temperature} - \text{min. temperature}} \right) \times E$$

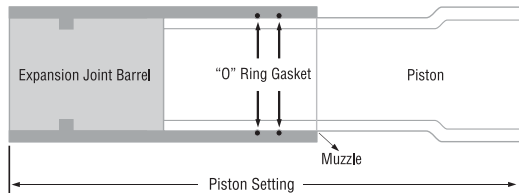

| Size (in) | Compressed Length (in) | Travel (in) |
|-----------|------------------------|-------------|
| 1/2 | 8.00 | 4 |
| 3/4 | 8.00 | 4 |
| 1 | 8.50 | 4 |
| 1-1/4 | 9.00 | 4 |
| 1-1/2 | 9.00 | 4 |
| 2 | 9.25 | 4 |
| 2-1/2 | 9.25 | 4 |
| 3 | 14.25 | 8 |
| 3-1/2 | 14.25 | 8 |
| 4 | 14.25 | 8 |
| 5 | 14.25 | 8 |
| 6 | 14.25 | 8 |

COMMON MISTAKES

Three common mistakes are:

1. Forgetting to use expansion joints.
2. Not using enough expansion joints.
3. Overtightening of support straps.

It is more cost effective to use more expansion joints than needed, rather than too few. It is difficult to correct the problem after conductors are installed and in service. Failure to accommodate expansion/contraction may result in pipe fracture.

TECHNICAL INFORMATION EXPANSION FITTINGS

INSTALLATION OF EXPANSION JOINTS

USING EXPANSION JOINTS

Proper functioning of an expansion joint depends on three procedures:

1. The correct placement of the expansion joint.
2. The proper installation of Scepter Rigid PVC Conduit and the expansion joint.
3. The proper placement and fastening of support straps.

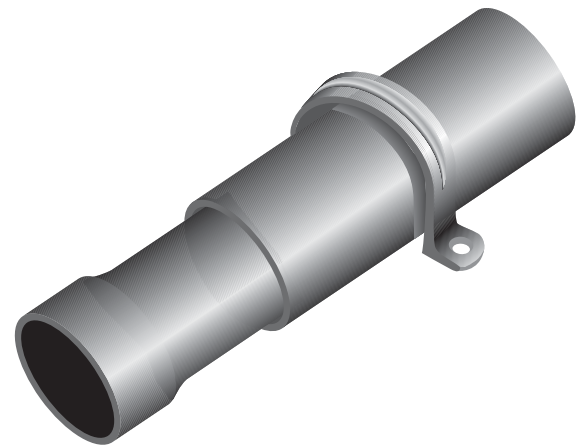

One Expansion Joint - Figure 1

If only one expansion joint is needed between two boxes, the barrel of the joint should be rigidly fastened close to the first box. Scepter Rigid PVC Conduit should then be loosely supported with straps, allowing the conduit to move freely as it expands and contracts.

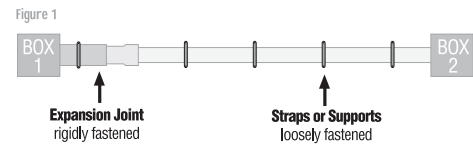

Two Expansion Joints - Figure 2

If two expansion joints are needed, the joints should be firmly fastened back to back at the centre of the run. Scepter Rigid PVC Conduit should be loosely supported with straps, allowing the conduit to move freely as it expands and contracts.

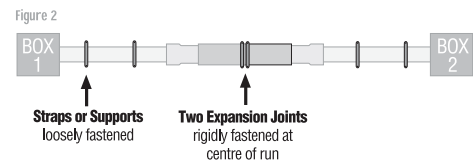

Two Expansion Joints (Alternative) - Figure 3

Alternatively, the centre of the run and the two expansion joints (located at the boxes) should be rigidly fastened. All other support straps should be loosely fastened.

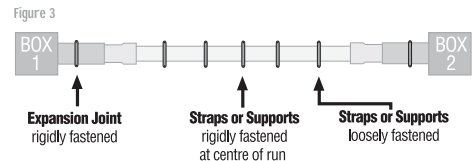

Three or More Expansion Joints - Figure 4

If more than two joints are needed in a very long run, they should be put in a series, one after the other. Each barrel must be rigidly fastened while conduit is loosely supported with straps allowing the conduit to move freely as it expands and contracts. When installed in a series, each section acts independently of the other. Spacing of conduit supports must be in accordance with NEC Article 347-8. (See Table on Support Spacing)

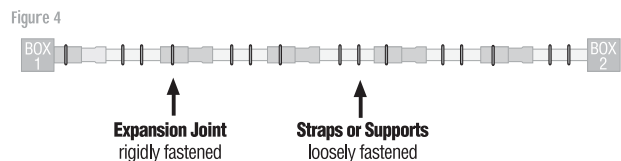

INSTALLATION RECOMMENDATIONS

- Expansion joints should be mounted so the piston can travel in a straight line in the barrel. If the alignment is not straight, the piston will bind, preventing the joint from functioning correctly.
- The expansion joint barrel should be clamped tight, but the conduit mounted loose enough in its hangers to allow for movement as it expands and contracts.
- Scepter nonmetallic straps are correctly sized and designed for proper support, and must be used to secure the conduit.
- When expansion joints are used in a vertical position, the piston should be mounted in a downward position so dirt cannot deposit between the barrel and piston at the muzzle of the expansion joints.

CONDUIT FITTINGS

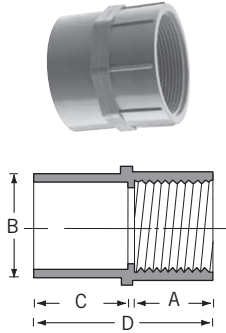

| Size inches | Part Number | Product Code | A inches | B inches | C inches | D inches |
|-------------|-------------|--------------|----------|----------|----------|----------|
|-------------|-------------|--------------|----------|----------|----------|----------|

Female Adapters NPT Tapered Thread

| | | | | | | |
|-------|------|--------|-------|-------|-------|-------|
| 1/2 | FA10 | 077041 | 0.800 | 0.620 | 0.825 | 1.725 |
| 3/4 | FA15 | 077042 | 0.800 | 0.820 | 1.000 | 1.900 |
| 1 | FA20 | 077043 | 1.000 | 1.065 | 1.200 | 2.300 |
| 1-1/4 | FA25 | 077044 | 1.015 | 1.395 | 1.300 | 2.425 |
| 1-1/2 | FA30 | 077045 | 1.050 | 1.575 | 1.290 | 2.440 |
| 2 | FA35 | 077046 | 1.075 | 2.050 | 1.375 | 2.550 |
| 2-1/2 | FA40 | 077047 | 1.675 | 2.470 | 1.985 | 3.760 |
| 3 | FA45 | 077048 | 1.630 | 3.090 | 2.150 | 4.100 |
| 3-1/2 | FA50 | 077049 | 1.800 | 3.540 | 2.000 | 3.985 |
| 4 | FA55 | 077050 | 1.755 | 4.025 | 2.185 | 4.210 |
| 5 | FA60 | 077051 | 2.065 | 5.035 | 3.000 | 5.240 |
| 6 | FA65 | 077052 | 2.065 | 6.045 | 3.000 | 5.235 |

| Size inches | Part Number | Product Code |
|-------------|-------------|--------------|
|-------------|-------------|--------------|

End Caps



| | | |
|-------|-------|--------|
| 1/2 | CAP10 | 077421 |
| 3/4 | CAP15 | 077422 |
| 1 | CAP20 | 077423 |
| 1-1/4 | CAP25 | 077424 |
| 1-1/2 | CAP30 | 077425 |
| 2 | CAP35 | 077426 |
| 2-1/2 | CAP40 | 077427 |
| 3 | CAP45 | 077428 |
| 3-1/2 | CAP50 | 077429 |
| 4 | CAP55 | 077430 |
| 5 | CAP60 | 077431 |
| 6 | CAP65 | 077432 |

Reducer Bushings

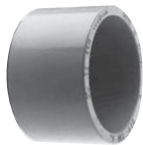

| | | |
|---------------|--------|--------|
| 3/4 x 1/2 | 1805 | 077300 |
| 1 x 1/2 | 1805-1 | 077301 |
| 1 x 3/4 | 1806 | 077302 |
| 1-1/4 x 3/4 | 1807-1 | 077303 |
| 1-1/4 x 1 | 1807 | 077304 |
| 1-1/2 x 1 | 1808-1 | 077305 |
| 1-1/2 x 1-1/4 | 1808 | 077306 |
| 2 x 1 | 1809-1 | 077313 |
| 2 x 1-1/4 | 1809 | 077307 |
| 2 x 1-1/2 | 1810 | 077308 |
| 2-1/2 x 2 | 1811 | 077309 |
| 3 x 2 | 1812-1 | 077310 |
| 3 x 2-1/2 | 1812 | 077311 |
| 4 x 2 | 1813-1 | 077319 |
| 4 x 3 | 1813 | 077312 |
| 4 x 3-1/2 | 1814 | 077317 |