

CPVC HOT & COLD WATER DISTRIBUTION SYSTEMS

1/2" - 4" (12mm - 100mm)

AquaRISE®

While contractors and engineers have traditionally had few viable alternatives to increasingly-expensive metal for their water distribution systems, IPEX Inc. now offers a solution that ensures time and cost-savings without sacrificing the strength or performance. With AquaRise, IPEX introduces a CPVC hot and cold water distribution system that comes with reduced material costs, offers superior features and exceeds all industry testing standards.

A SOLID ALTERNATIVE TO METAL

Compare AquaRise to traditional metal systems, and AquaRise proves itself a strong, highly-engineered and affordable improvement over copper. Manufactured tough and robust, AquaRise performs as well as—and in many cases, better than—metal, offering a rugged system that exceeds all required standards. At the same time, AquaRise costs less than copper, yielding significant project savings. Thanks to its superior durability, these cost savings will pay off even more in years to come. AquaRise's corrosion resistance ensures a longer, maintenance-free life and better performance over the long-term.

PROJECT SAVINGS

IPEX created AquaRise to be a system that saves valuable time and money on the job site. Its simple solvent cement system makes AquaRise fast and easy to assemble. No expensive certified training is needed, and no flames or torches are required during installation, reducing costly job site safety risks. In addition, AquaRise sweats less than metal pipe due to its excellent insulating properties. As a result, it can reduce the need for insulation, lowering overall job costs. AquaRise also represents a lower risk of job site theft.

Proven strength, competitive price, easy installation — what all this adds up to is significant time and cost-savings for contractors and building owners over the long term.

APPLICATIONS

- Potable Water Distribution
- Hot Water Recirculating Systems

STANDARDS



Conforms to ASTM F442



Certified to CSA B137.6



NSF 61



CAN/ULC-S02.2



DID YOU KNOW?

AquaRise interior and exterior walls remain smooth in virtually any service condition, unlike metal which, over time, will rust, pit, scale and corrode.



ADVANTAGES

- 1 Proven to Exceed Toughest Standards**

Thanks to its advanced materials and rugged design, AquaRise provides long term hydrostatic pressure ratings of 150 psi at 160°F and 400 psi at 73°F. Meeting the requirements of CSA B137.6, AquaRise passes the punishing burst pressure tests conforming to ASTM F442.
- 2 Better Long-Term Performance**

Unlike metal piping which may pit, scale and degrade over time, AquaRise's rugged thicker walls and excellent corrosion resistance ensure years of consistent flow and maintenance-free performance, even in demanding hot water recirculation applications.
- 3 Fully-Certified Compliance**

Designed to be safely used in hot and cold water distribution systems, AquaRise complies with the following:

 - CSA B137.6 (CPVC Pipe, Tubing and Fittings for Hot and Cold Water Distribution Systems)
 - NSF 61 (Potable Water Classification)
 - CAN/ULC-S102.2
- 4 Full Flame & Smoke Approvals**

Listed to the CAN/ULC-S102.2 standard, AquaRise achieved a Flame Spread rating of not more than 25 and a Smoke Development classification of not more than 50. Unlike competitive products, AquaRise does not need insulation to achieve certification. Ideal for noncombustible applications, AquaRise is code compliant to the following sections of the National Building Code of Canada:

 - High-rise buildings as defined by NBC article 3.2.6
 - Air plenums as defined by NBC article 3.6.4.3
 - Noncombustible buildings as defined by NBC article 3.1.5.16
- 5 Permanent Joining System**

IPEX supplies high quality CPVC cement, primer and applicators for enabling tough, permanent welded pipe-fitting connections.

SPECIFICATIONS

AQUARISE PIPE, VALVES AND FITTINGS

AquaRise pipe and fittings are certified to CSA B137.6. When used in noncombustible construction, high-rise buildings and air plenums, AquaRise pipe shall be tested and listed in accordance with CAN/ULC S102.2 and clearly marked with the certification logo indicating a Flame Spread Rating not more than 25 and a Smoke Developed Classification not exceeding 50. Pipe shall be SDR 11 thickness and IPS outside diameter.

FIRESTOPPING DEVICES

Firestopping systems shall be listed under CAN/ULC S115 and tested with a pressure differential of 50 Pa. Certified firestopping devices are required whenever the system penetrates a vertical or horizontal fire separation.

ONE-STEP & TWO STEP SOLVENT CEMENTS

IPEX has made a significant change to the current solvent cement products to be used with AquaRise Domestic Water Piping. The product offering has been modified to now offer two customized solvent cements for small and large size ranges. Both products are certified to CSA B137.6, listed to NSF 61 and sold as a kit coming complete with necessary applicators and installation instructions.

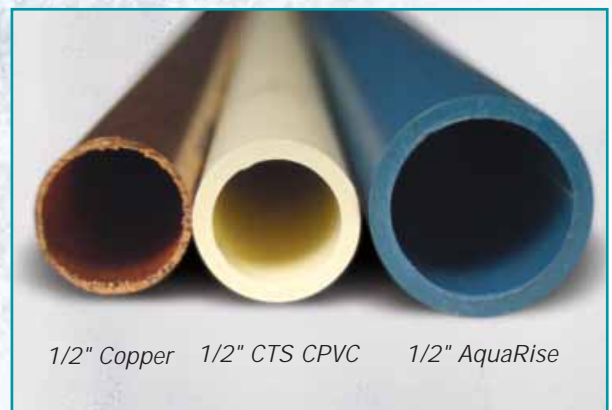

1/2" Copper 1/2" CTS CPVC 1/2" AquaRise

PIPE DIMENSIONS AND WEIGHTS

AquaRise pipe is produced (1/2" through 4") in SDR 11 dimensions with IPS (Iron Pipe Size) outside diameters. The SDR (Standard Dimension Ratio) value means that all sizes of pipe maintain a constant ratio between the pipe outside diameter and minimum wall thickness. This results in all diameters carrying the same pressure ratings of 100 psi at 180°F and 400 psi at 73°F.

AquaRise Pipe Dimensions & Weights IPS / SDR 11 (Imperial)

Nominal Size (Inches)	Average OD (Inches)	Average ID (Inches)	Average Wall Thickness (inches)	Weight - Empty lb/ft
1/2	0.840	0.687	0.076	0.130
3/4	1.050	0.859	0.095	0.202
1	1.315	1.076	0.120	0.319
1-1/4	1.660	1.358	0.151	0.507
1-1/2	1.900	1.555	0.173	0.663
2	2.375	1.943	0.216	1.037
2-1/2	2.875	2.352	0.261	1.519
3	3.500	2.864	0.318	2.250
4	4.500	3.633	0.434	3.722

AquaRise Pipe Dimensions & Weights IPS / SDR 11 (Metric)

Nominal Size (mm)	Average OD (mm)	Average ID (mm)	Average Wall Thickness (mm)	Weight - Empty Kg/m
12	21.3	17.5	1.9	0.19
19	26.7	21.8	2.4	0.30
25	33.4	27.3	3.0	0.47
32	42.2	34.5	3.8	0.76
38	48.3	39.5	4.4	0.99
50	60.3	49.4	5.5	1.55
63	73.0	59.7	6.6	2.26
75	88.9	72.7	8.1	3.35
100	114.3	92.3	11.0	5.55

MATERIAL DESCRIPTION

AquaRise thermoplastic pipe and fitting material is a specially formulated Chlorinated Polyvinyl Chloride (CPVC) compound and carries an ASTM D1784 Cell Class of 24447. It is characterized by distinctive physical properties and is resistant to corrosion and attack from a variety of chemicals. CPVC has proven to be an excellent piping material for hot and cold water distribution and similar applications above the temperature range of PVC.

Physical Properties

Property	CPVC	ASTM Std.
Specific Gravity	1.55	D792
IZOD Impact Strength (ft. lbs./inch, notched)	3.0	D256A
Modulus of Elasticity, @ 73°F, psi	4.23 x 10 ⁵	D638
Ultimate Tensile Strength, psi	8,400	D638
Compressive Strength, psi	9,600	D695
Poisson's Ratio	.35 - .38	-
Working Stress @ 73°F, psi	2,000	D1598
Hazen-Williams C Factor	150	-
Coefficient of Linear Expansion in./in. °F)	3.4 x 10 ⁻⁵	D696
Thermal Conductivity BTU/hr./ft ² /°F/in.	0.95	C177
Limiting Oxygen Index	60%	D2863
Electrical Conductivity	Non Conductor	

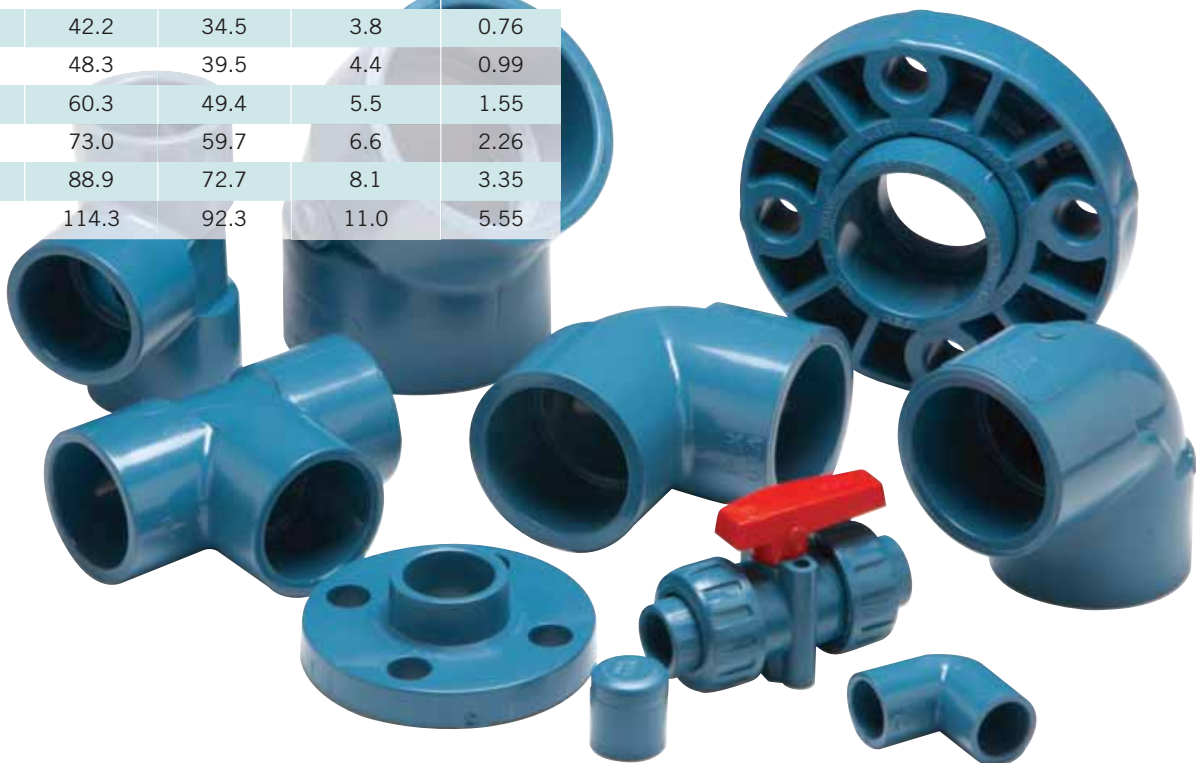

PRODUCT SELECTION CHART

	Dimension inches	Product Code
U Do-It Manifold Soc x Sp x Soc	3/4 x 3/4 x 1/2 x 1/2	359060
	3/4 x 3/4 x 1/2	359061

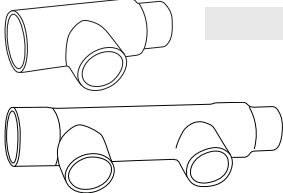

	Dimension inches	Product Code
Deburring Tools	1/2, 3/4, 1	359044
	1-1/4 to 4	359062

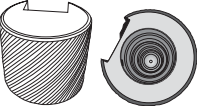

	Dimension inches	Dimension mm	Product Code
Repair Adapter FT SS Reinforced x Pipe Stub	1	25	359063
	1-1/4	32	359064
	1-1/2	40	359077
	2	50	359065
	3	75	359066

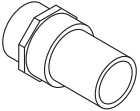

	Dimension inches	Dimension mm	Product Code
Repair Flange Solid Style Flange x Pipe Stub	2-1/2	65	359057
	3	75	359058
	4	100	359059



	Dimension inches	Dimension mm	Product Code
Maintenance Coupling*	1	25	359204
	1-1/4	32	359205
	1-1/2	40	359206
	2	50	359207
	2-1/2	65	359208
	3	75	359209
	4	100	359210

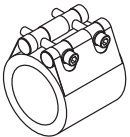

*Torque wrench kits are available through IPEX

	Dimension inches	Dimension mm	Product Code
Full Pressure Flange Kit	2-1/2	65	359040
	3	75	359041

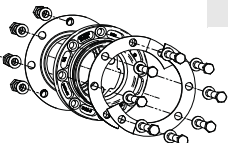

	Description imperial	Description metric	Product Code
Aquarise One-Step Cement*	Pint	473 ml	359086
	*FOR USE ON 1/2" TO 2"		



	Description imperial	Description metric	Product Code
Aquarise Two-Step Cement w/Primer*	Quart	946 ml	359087
	Pint	473 ml	primer
*FOR USE ON 2-1/2", 3" & 4"			



	Description imperial	Product Code
Can-Mate Daubers (with telescoping stem)	CM-75 (pipe sizes 1/2" - 1-1/4")	074436
	CM-150 (pipe sizes 1-1/2" - 3")	074437



	Description imperial	Product Code
Cap Daubers	DP 50 (pipe sizes 1/2" - 1")	074455
	DP 150 (pipe sizes 1-1/4" - 3")	074421
	DQ 50 (pipe sizes 1/2" - 1")	074193
	DQ 150 (pipe sizes 1-1/4" - 3")	074422

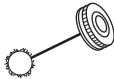

Note: DP fits Pint cans and DQ fits Quart cans

	Description imperial	Description metric	Product Code
Swab	4"	100 mm	074456
	6" +	150 mm	074317

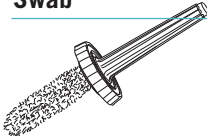

	Description	Product Code
Aquarise Superswab Replacement	Swab is disposable and replaceable	359826

