

Wall Plates Types, Finishes and Configurations



P8
Smooth Nylon



P1G
Smooth Nylon



HPS1WA
Smooth Nylon



P1X
Smooth Nylon



P1B
Smooth Nylon



P1R
Smooth Nylon



SPJ26
Smooth Nylon



S1
Stainless Steel



B1
Solid Brass



CH8
Chrome Plated Steel



BP1
Brass Plated Steel



A1
Aluminum



PJ8C
Premarked Nylon



IGP8
Premarked Nylon



S8MEV
Premarked Stainless Steel

Actual product may vary from photos shown above.



Only The Best Materials

Hubbell offers a wide variety of configurations available in high-impact nylon and metal wall plates. In 1981, Hubbell was the first manufacturer to introduce nylon wall plates. Hubbell only offers plastic plates made of a high-impact material and does not offer wall plates made of materials that may be subject to breakage in abusive environments.

Hubbell offers only the best grade of stainless steel type 302/304, which is 18% chromium, 8% nickel, and non-magnetic providing superior corrosion resistance versus type 430 stainless steel. When you specify Hubbell wall plates you can be assured of the highest quality materials providing extended life in the most abusive environments.

High-Impact Smooth Nylon

For Commercial, Institutional, Hospital and Industrial Applications.

- High-impact resistance limits access to live parts due to breakage.
- Contemporary smooth finish and contoured edges enhance installation appearance.
- Captive screw feature holds mounting screw in place for quick and easy installation.
- Positive “Bow” feature assures flush installation.
- Self-extinguishing nylon material.
- Smooth finish without recessed lines is easy to clean and maintain attractive appearance.
- Highly resistant to solvents and cleaning solutions providing long life in the harshest environments.
- Non-conductive material.

Smooth Metal 302/304 Super Stainless Steel

18% Chromium, 8% Nickel

For Commercial, Institutional, Hospital and Industrial Applications.

- Provides extended life in abusive and corrosive environments.
- Contemporary smooth finish and contoured edges enhance installation appearance.
- Smooth finish without recessed lines is easy to clean and maintain attractive appearance.
- Satin finish hides fingerprint marks.
- Non-magnetic for static-free requirements.

Smooth Solid Brass, Anodized Aluminum and Metallic Plated Steel

For Commercial, Institutional and Industrial Applications.

Smooth Solid Brass

- Provides a plush appearance and durability of metal.
- Finish is coated to inhibit oxidation.

Smooth Solid Anodized Aluminum

- Non-magnetic and corrosion resistant providing suitability for a wide range of applications.
- Finish is coated to inhibit oxidation.

Metallic Plated Steel

- Available in a choice of chrome and brass finishes.

Custom Metal Wall Plates

Hubbell offers 40 custom configurations available in 5 metal finishes from 2-gang up to and including 8-gang configurations. These custom openings can be configured in any combination to meet your specific requirements.

Wall Plates

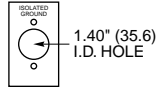
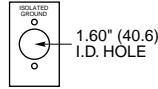
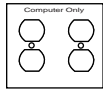
Premarked Nylon Wall Plates*Hot Stamped, Black Recessed Lettering***IGP8****IGHP51****IGP7****IGP720****PJ8CO
PJ8C****PJ82CO****SPJ26C
PJ26C****Orange Nylon Standard Size Wall Plates**
Hot Stamped, Recessed Black Lettering
“ISOLATED GROUND”

Description	Catalog Numbers
1-gang, 1 duplex.	IGP8
1-gang, 1 duplex, no marking.	P8OR
1-gang, rectangular opening.	IGHP51
1-gang, 1 opening for face diameter 1.36"-1.39" (34.5-35.3).	IGP7
1-gang, 1 opening for 20A and 30A Twist-Lock® with face diameter 1.55"-1.58" (39.4-40.1).	IGP720

Nylon Mid-size Wall Plates
Hot Stamped, Recessed Black Lettering
“COMPUTER ONLY”

Description	Catalog Numbers
Orange, 1-gang, 1 duplex.	PJ8CO
Orange, 2-gang, 2 duplex	PJ82CO
Ivory, 1-gang, 1 duplex.	PJ8C
Blue, 1-gang, rectangular opening,	SPJ26C
Blue, 1-gang, 1 rectangular opening, no marking.	SPJ26
Ivory, 1-gang, rectangular opening.	PJ26C

Mid-size plate dimensions shown on page K-28.

Wall Plates

Technical Information

Specifications

Listings

Non-Metallic Plates	UL Standard 514D, #E92074.
Metallic Plates	UL Standard 514D, #E31999.
Certification	CSA Standard C22.2 No. 42.1. CSA File LR18416.

Nylon Plate

Thickness	.06" (1.5).
Mounting Screw(s)	Brass (painted slotted screw head).
Feature	Captive mounting screw hole.
Operating Temperature	-40°C to 85°C.
Appearance	Smooth.

302/304 Stainless Steel (18% Chromium, 8% Nickel) Plate

Thickness	.04" (0.9) nominal.
Mounting Screw(s)	302/304 stainless steel (18% chromium, 8% nickel). Slotted screw head.
Appearance	Smooth satin finish (without lines).

Brass (70% Copper, 30% Zinc) Plate

Thickness	.04" (1.0).
Mounting Screw(s)	Brass (70% Copper, 30% Zinc). Slotted screw head.
Appearance	Smooth satin finish (without lines).

Aluminum Plate

Thickness	.05" (1.3).
Mounting Screw(s)	Aluminum slotted head.
Appearance	Smooth satin finish, clear anodized (without lines).

Brass Plated Steel Plate

Thickness	.03" (.8) nominal.
Mounting Screw(s)	Brass slotted head.
Appearance	Smooth satin finish (without lines), coated to inhibit oxidation.

Chrome Plated Steel Plate

Thickness	.03" (.8) nominal.
Mounting Screw(s)	Zinc plate steel, slotted head.
Appearance	Smooth (without lines), coated to inhibit oxidation.

Wall Plates

Technical Information

Product Dimensions

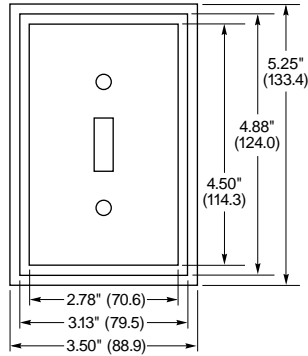

Standard Size

- 1-Gang 4.5" (114.3) x 2.78" (70.6)
- 2-Gang 4.5" (114.3) x 4.60" (116.8)
- 3-Gang 4.5" (114.3) x 6.41" (162.8)
- 4-Gang 4.5" (114.3) x 8.22" (208.8)
- 5-Gang 4.5" (114.3) x 10.03" (254.8)
- 6-Gang 4.5" (114.3) x 11.81" (300.0)
- 7-Gang 4.5" (114.3) x 13.63" (346.2)
- 8-Gang 4.5" (114.3) x 15.44" (392.1)

Mid-Size

- 1-Gang 4.88" (124.0) x 3.13" (79.5)
- 2-Gang 4.88" (124.0) x 4.94" (125.5)
- 3-Gang 4.88" (124.0) x 6.75" (171.5)

Jumbo

- 1-Gang 5.25" (133.4) x 3.50" (88.9)
- 2-Gang 5.25" (133.4) x 5.31" (134.9)
- 3-Gang 5.25" (133.4) x 7.12" (180.8)

Wall Plate Openings and Mounting Dimensions

#6-32 Oval Head Screws Typical

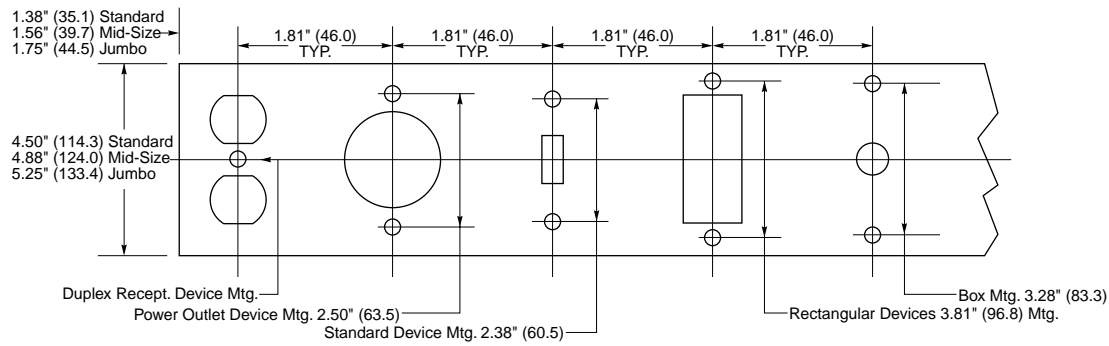

Specifications are subject to change without notice.