

750V DC Square Body Fuses

Size: 121

Features/Benefits:

- Blown-fuse indicator
- Square ceramic body
- Full range D.C. operation
- Bladed and tapped versions standard

Catalog Numbers, Ratings

Size	Current Rating I_N (A)	Interrupting I_N (A)	Maximum I^2t @900V=L/R 40ms		Watts Loss		Catalog Number	Ref. No.
			$I_p=10I_N$	$I_p=50I_N$	$0.8 I_N$	I_N		
121	200	@ 750V DC	755000	150000	20.5	37.5	CC 7,5 gRC 121 EF 0200	A086710
	250	100kA L/R = 100ms	1250000	250000	25.5	46.7	CC 7,5 gRC 121 EF 0250	M085203
	200	@900V DC	755000	150000	20.5	37.5	CC 7,5 gRC 121 TTF 0200	N085250
	250	100kAL/R = 40ms	1250000	250000	25.5	46.7	CC 7,5 gRC 121 TTF 0250	Q085252

Microswitch: MC 3E 1-5N Ref. Number: D310020
Contact factory for holder

Dimensions

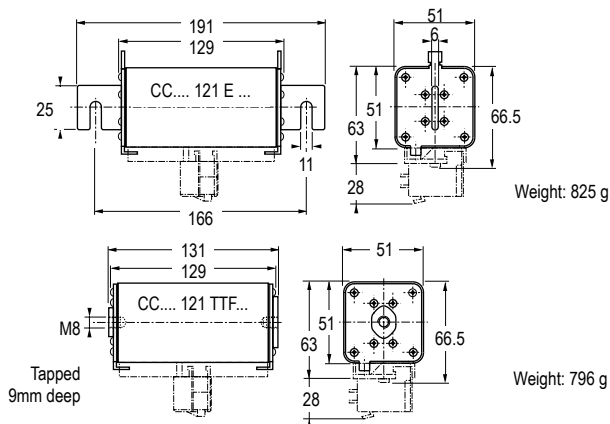

Ratings:

- Volts** : 750VDC
- : 900VDC
- Amps** : 200 & 250A
- IR** : 100kA I.R.
- L/R** : 100mSec (750V)
- L/R** : 40mSec (900V)