



Introduction

Color-Keyed® Special Lugs for Special Problems — Angled, Shaped and Flared the Way You Need Them

Thomas & Betts can solve your difficult wire bending and terminating problems in confined power distribution panels, switchgear and motor control enclosures.

We have the design and production capability to deliver exactly the type lug you need, shaped the way you need.

- Straight, 45° and 90° angle
- Stacking or non-stacking
- Narrow-tongue or standard
- Tin, silver and nickel plating available

Thomas & Betts offers an extensive line of copper Color-Keyed® lugs for #8 AWG through 1000 kcmil flex and code cables. The lug tongues are modified in several different configurations to meet your exact needs: 45° and 90° bend angles, narrow-tongues to fit into circuit breakers, offset tongues to stack two cables and special stud hole drilling. These special configurations let you:

1. Run cable directly to the bus bar with no bending
2. Terminate into very narrow spaces
3. Utilize minimal bus bar space

The specially designed lugs help you “clean up” your cabling in crowded enclosures.

The pictures show some examples of how and where the lugs can be used.



Customized Color-Keyed® Connectors for Copper Cables

- Standard and special tongue angles, stacking and non-stacking, bolt holes sizes and centers, protective platings.
- Specially modified one and two hole copper Color-Keyed® compression lugs, Series 54100, 54200, 54850BE and 54930BE for flex and code copper stranded cables. Material: high-conductivity wrought copper.
- Minimum order quantity: Standard package quantity by cable size. Consult your Regional Sales Office for price and delivery. All customized lugs are made to order and cannot be cancelled.



Introduction

Order Form (to be scanned or photocopied)

Catalogue No. _____ Qty. _____

Design Controls and Requirements

All "MADE-UP" catalogue numbers start with a standard or basic catalogue number and are followed by the customer-required extra features: Tongue shape, bolt hole size, distance between bolt holes, stacking, plating and inspection hole (peep hole). A code letter or a number has been assigned to each extra feature. See CODE CABLE TABLE below.

- Notes: 1) Lack of any of the extra features on the "MADE-UP" catalogue number means that the standard Cat. No. features are prevalent.
 2) If either bolt hole size or distance between bolt holes needs to be changed from standard Cat. No., both code numbers will appear on the "MADE-UP" Cat. No. (see example below).

Cat. No. 54212UB0416BSP

54212	UB	04	16	B
2 hole 4/0 Cu lug basic cat. no.	90° bend	1/4 in. bolt hole	1 in. hole spacing	bottom stack

Code Cable Table

Tongue Shape		Bolt Holes Size .020		Code	Bolt Hole Centers		Stacking		Finish (Plating)		Inspection Hole (Long Barrel)		Inspection Hole (Short Barrel)	
Type	Code				Center to Center (in.)	Code	Type	Code	Type 1	Code	I.D.	Code	I.D.	Code
45°	UF	#8	0.173	02	1/2	08	Top	T**	Silver	SP	Peep Hole	PH	Blind End	BE
90°	UB	#10	0.204	03	5/8	10	Bottom	B	Lead	LP				
Blank	BT	1/4	0.281	04	3/4	12			Nickel	NP	150°			
(No Bolt Hole)		5/16	0.344	05	7/8	14			Plain Finish	PF				
		3/8	0.406	06	1	16			No Marking	NM				
		1/2	0.531	08	1-1/8	18								
		5/8	0.656	10	1-1/4	20								
		3/4	0.812	12	1-3/8	22								
		1/8	0.937	14	1-1/2	24								
		1	1.062	16	1-5/8	26								
					1-3/4	28								
					*1-7/8	30								
					*2	32								

* These bolt centers are not available for bolt holes larger than 13/16 in.
 ** Not required for 45° & 90° Top Stacking.

Cable	Code	<input type="checkbox"/>
	Weld	<input type="checkbox"/>
<input type="checkbox"/> #8	<input type="checkbox"/> #6	<input type="checkbox"/> #4
<input type="checkbox"/> #2	<input type="checkbox"/> #1	<input type="checkbox"/> 1/0
<input type="checkbox"/> 2/0	<input type="checkbox"/> 3/0	<input type="checkbox"/> 4/0
<input type="checkbox"/> 250 kcmil & up (Code cable Only)		

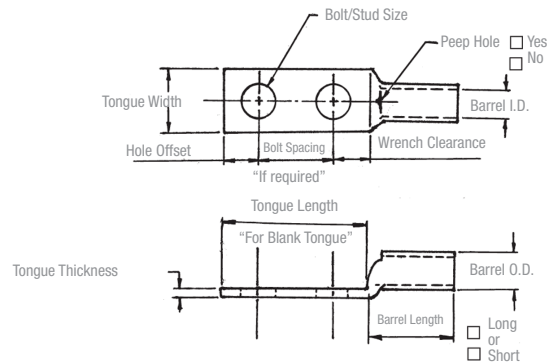

Introduction

Tongue Specifications — See Chart “A” for Dimensions

Stud Sizes		
<input type="checkbox"/> #8	<input type="checkbox"/> #10	<input type="checkbox"/> 1/4 in.
<input type="checkbox"/> 5/16 in.	<input type="checkbox"/> 3/8 in.	<input type="checkbox"/> 1/2 in.
<input type="checkbox"/> 5/8 in.	<input type="checkbox"/> 3/4 in.	<input type="checkbox"/> 7/8 in.
<input type="checkbox"/> 1 in.		



Chart A

Nominal Bolt Hole	Hole Offset	Min. Wrench Clearance	Tongue Width Cable Size										
			#8 Code #8 Weld	#6 Code #6 Weld	#4 Code	#2 Code #4 Weld	#1 Code #2 Weld	1/0 Code #1 Weld	2/0 Code 1/0 Weld	3/0 Code 2/0 Weld	4/0 Code 3/0 Weld	250 Code	
#8	0.173	0.200	0.240	0.406	0.437	0.562	0.593	0.672	0.750	0.825	0.937	1.030	1.125
#10	0.204	0.218	0.250										
1/4	0.281	0.250	0.312	0.469	0.500		0.675						
5/16	0.344	0.375	0.406	0.562	0.562	0.750	0.750						
3/8	0.406	0.375	0.440	0.578	0.578	0.594							
1/2	0.531	0.500	0.562										
5/8	0.656	0.812	0.875										
3/4	0.812	0.750	0.770	-	-	-	-	-	-	-	-	-	-
*7/8	0.937	0.875	0.890										
*1	1.062	0.937	1.000										

* These bolt holes are available in one hole lug only. Dimensions are in inches.

Chart B

Cable Size	Tongue Thickness	Straight Lug Barrel Length		Barrel		Dim. "X" Stacked Lugs			Dim. "Y"		Dim. "H"	
		Short	Long	O.D.	I.D.	Straight	45°	90°	Short	Long	Short	Long
#8	0.080	0.635	0.935	0.260	0.180	0.158	0.478	0.394	0.595	0.808	0.779	1.079
#6	0.081	0.675	0.975	0.296	0.215	0.134	0.544	0.432	0.587	0.799	0.767	10.67
#4	0.099	0.685	0.985	0.365	0.266	0.175	0.622	0.502	0.637	0.849	0.838	1.138
#2	0.108	0.815	1.115	0.410	0.302	0.216	0.649	0.535	0.711	0.923	0.958	1.258
#1	0.106	0.825	1.275	0.467	0.361	0.212	0.731	0.592	0.710	1.028	0.956	1.406
1/0	0.125	0.975	1.325	0.520	0.396	0.250	0.789	0.646	0.794	1.042	1.075	1.425
2/0	0.125	0.965	1.315	0.571	0.446	0.250	0.859	0.696	0.829	1.077	1.125	1.475
3/0	0.125	1.085	1.435	0.632	0.507	0.250	0.946	0.757	0.900	1.148	1.225	1.575
4/0	0.137	1.255	1.705	0.701	0.564	0.274	1.031	0.826	1.015	1.333	1.387	1.837
250	0.137	1.375	1.925	0.766	0.629	0.274	1.123	0.891	1.085	1.474	1.487	2.037
300	0.153	1.900	2.675	0.850	0.660	0.459	1.226	0.975	1.180	1.726	1.924	2.679
350	0.177	2.090	2.896	0.926	0.720	0.531	1.333	1.103	1.267	1.830	2.096	2.896
400	0.173	2.460	2.980	0.960	0.757	0.519	1.370	1.085	1.551	1.913	2.484	2.984
500	0.218	2.670	3.610	1.100	0.852	0.654	1.514	1.225	1.629	2.266	2.669	3.619
600	0.244	2.900	3.490	1.200	0.926	0.732	1.630	1.325	1.762	2.147	2.897	3.497
700	0.228	2.784	-	1.255	0.997	0.684	1.662	1.375	1.780	-	3.011	-
750	0.270	3.050	3.925	1.330	1.030	0.810	1.745	1.455	1.827	2.434	3.050	3.925
800	0.266	3.213	-	1.375	1.079	0.800	1.728	1.625	1.952	2.787	3.213	4.554
900	0.313	3.450	4.550	1.500	1.145	0.940	1.900	1.650	2.065	-	1.387	-
1,000	0.297	3.356	4.500	1.550	1.203	0.890	2.070	1.675	2.031	2.787	1.487	4.506

Stacking lugs are available for one bolt only. Consult your Regional Sales Office for details. Straight: 700 kcmil & up; 45°: 400 kcmil & up; 90°: 500 kcmil & up. Dimensions are in inches.

Introduction

Tongue Specifications — See Chart “A” for Dimensions

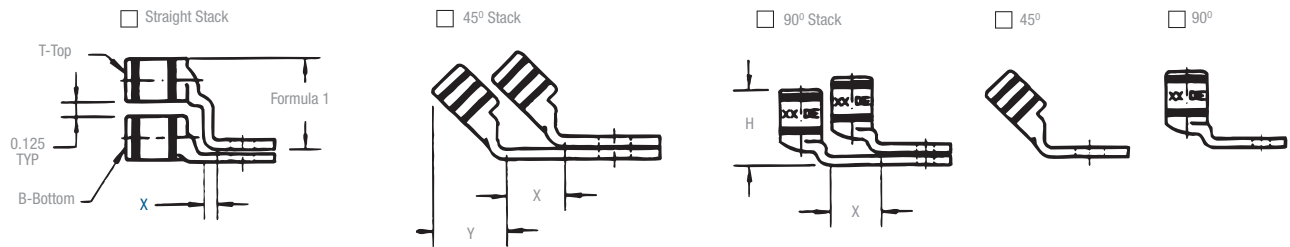

Formula 1 = (0.125 + 2 (OD) + 0.037 – Tongue Thickness)

Chart C

Tongue Width 0.030 / Code Cable Size											
Bolt Hole Size	300 kcmil 4/0 Weld	350 kcmil	400 kcmil	500 kcmil 400 Weld	600 kcmil 500 Weld	1325/24	700 kcmil	750 kcmil	800 kcmil	900 kcmil	1000 kcmil
#8	-	-	-	-	-	-	-	-	-	-	-
#10	-	-	-	-	-	-	-	-	-	-	-
1/4	1.250	1.355	1.410	1.605	1.745	1.805	1.840	1.935	2.010	2.180	2.265
5/16											
3/8											
1/2											
5/8											
3/4	-	-	-	-	-	-	-	-	-	-	
*7/8	-	-	-	-	-	-	-	-	-	-	-
*1	-	-	-	-	-	-	-	-	-	-	-

* These bolt holes are available in one hole lug only. Dimensions are in inches.



Compression Connectors for Copper Conductors

Two-Way Splice Connectors — Standard Barrel Certified to 600 V and Recommended up to 35 kV[‡]

Two-way connectors provide high-pullout values, are easy to insulate and provide a low-resistance connection of high quality and low installed cost.

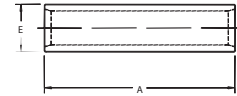

Material: High-Conductivity Wrought Copper
Finish: Electro-Tin Plated

Cat. No.	Wire Size		Dimensions in. (mm)		Die Set Cat. No.	Colour Code
	Code Cable	Flex Cable Classes G, H, I, K, M*	A	E		
54504	#8 AWG	#8 AWG, 37/24, #8 Weld	1.00 (25.4)	0.27 (6.9)	21	Red
54505	#6 AWG	#6 AWG, 61/24, #6 Weld, 133/0.014	1.00 (25.4)	0.30 (7.6)	24	Blue
54506	#4 AWG	#4 AWG, 91/24, 133/0.0177, 49/0.029	1.00 (25.4)	0.37 (9.4)	29	Grey
54507	#2 AWG	125/24, #4 Weld	1.25 (31.8)	0.41 (10.4)	33	Brown
54508	#1 AWG	#2 AWG, 150/24, 175/24, #2 Weld, 133/0.0223	1.50 (38.1)	0.47 (11.9)	37	Green
54509	1/0 AWG	225/24, #1 Weld, 133/0.0254	1.63 (41.4)	0.52 (13.2)	42	Pink
54510	2/0 AWG	1/0 AWG, 275/24, 1/0 Weld, 427/0.0155, 133/0.0282	1.75 (44.5)	0.57 (14.5)	45	Black
54511	3/0 AWG	2/0 AWG, 325/24, 2/0 Weld, 133/0.0316, 259/0.0227, 427/0.0177	1.75 (44.5)	0.63 (16.0)	50	Orange
53962	-	375/24, 179 kcmil, 133/0.0355, 259/0.0255, 427/0.0199	1.81 (46.0)	0.70 (17.8)		
54512	4/0 AWG	3/0 AWG, 450/24, 3/0 Weld, 703/0.0154	1.88 (47.8)	0.70 (17.8)	54	Purple
54513	250 kcmil	4/0 AWG, 550/24, 4/0 Weld, 133/0.0399, 259/0.0286, 637/0.0183	2.25 (57.2)	0.77 (19.6)	62	Yellow
53964	-	4/0 AWG, 550/24, 4/0 Weld, 133/0.0399, 259/0.0286, 637/0.0183	2.13 (54.1)	0.79 (20.1)		
54514	300 kcmil	300 kcmil, 775/24 (313 kcmil)	2.13 (54.1)	0.83 (21.1)	66	White
54515	350 kcmil		-	2.25 (57.2)	0.90 (22.9)	71
54516	400 kcmil	-	2.75 (69.9)	0.93 (23.6)	76	Blue
53968	-	300 kcmil, 775/24 (313 kcmil)	3.00 (76.2)	1.13 (28.7)	87	Brown
54518	500 kcmil		-	2.75 (69.9)		
54520	600 kcmil	-	3.00 (76.2)	1.18 (30.0)	94	Green
54522-TB	700 kcmil	1325/24 = 500/535 kcmil, 427/0.0342	3.25 (82.6)	1.23 (31.2)	99	Pink
53969	-		-	3.00 (76.2)		
54523-TB	750 kcmil	-	3.00 (76.2)	1.30 (33.0)	106	Black
54528	1000 kcmil	-	3.63 (92.2)	1.50 (38.1)	125	-
54530	1250 kcmil	-	4.13 (104.9)	1.67 (42.4)	140	-

[‡] For installations from 16 kV up to 35 kV, consult shielded cable manufacturers for stress relief and insulation requirements.
 *Consult your Regional Sales Office for complete list of flex cable class sizes M.

Tooling: pp. E4-E62
 Die Selector Chart: pp. E35-E50

Two-Way Splice Connectors — Long Barrel Certified to 600 V and Recommended up to 35 kV[‡]

Material: High-Conductivity Wrought Copper
Finish: Electro-Tin Plated

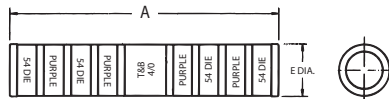

Cat. No.	Wire Size		Dimensions in. (mm)		Die Code	Colour Code
	Code Cable	Flex Cable Classes G, H, I, K, M	A	E		
54804	#8 AWG	#8, 37/24 = 14.9 kcmil	1.75 (44.5)	0.27 (6.9)	21	Red
54805	#6 AWG	#6, 61/24 = 24.6 kcmil	1.75 (44.5)	0.31 (7.9)	24	Blue
54806	#4 AWG	#4, 91/24 = 36.7 kcmil	1.75 (44.5)	0.39 (9.9)	29	Grey
54807	#2 AWG	125/24 = 50.4 kcmil	1.88 (47.8)	0.43 (11.0)	33	Brown
54808	#1 AWG	#2, 150/24 = 60.5 kcmil 175/24 = 70.6 kcmil	2.00 (50.8)	0.49 (12.4)	37	Green
54809	1/0 AWG	225/24 = 90.8 kcmil	2.00 (50.8)	0.54 (13.7)	42	Pink
54810	2/0 AWG	1/0, 275/24 = 111 kcmil	2.13 (54.1)	0.59 (15.0)	45	Black
54811	3/0 AWG	2/0, 325/24 = 131 kcmil	2.25 (57.2)	0.65 (16.5)	50	Orange
54812	4/0 AWG	450/24 = 182 kcmil	2.75 (69.9)	0.72 (18.3)	54	Purple
54813	250 kcmil	4/0, 550/24 = 222 kcmil	3.38 (85.9)	0.79 (20.1)	62	Yellow

[‡] For installations from 16 kV up to 35 kV, consult shielded cable manufacturers for stress relief and insulation requirements.

Cat. No.	Wire Size		Dimensions in. (mm)		Die Code	Colour Code
	Code Cable	Flex Cable Classes G, H, I, K, M	A	E		
54814	300 kcmil	250, 650/24 = 262 kcmil	3.50 (88.9)	0.87 (22.1)	66	White
54815	350 kcmil	-	3.75 (95.3)	0.95 (24.1)	71	Red
54816	400 kcmil	775/24 = 313 kcmil	3.75 (95.3)	0.98 (24.9)	76	Blue
54818	500 kcmil	350, 925/24 = 373 kcmil	4.75 (120.6)	1.11 (28.2)	87	Brown
54820	600 kcmil	1100/24 = 444 kcmil	4.25 (108.0)	1.21 (30.7)	94	Green
54823	750 kcmil	500, 1325/24 = 535 kcmil	4.75 (120.6)	1.34 (34.0)	106	Black
58524	-	1600/24 = 646 kcmil	5.00 (127.0)	1.39 (35.3)	106	Black
58526*	900 kcmil	750, 1925/24 = 777 kcmil	5.50 (139.7)	1.51 (38.4)	115	Yellow
54828	1000 kcmil	-	5.63 (143.0)	1.56 (39.6)	125	-
54833	1500 kcmil	-	5.63 (143.0)	1.56 (39.6)	125	-
54839	2000 kcmil	-	7.06 (179.3)	2.13 (54.1)	-	-

*CSA approved code cable only.

Tooling: pp. E4-E62
 Die Selector Chart: pp. E35-E50