

# Shield-Kon®

## One-Piece Connector

Maintains voltage and is easy to install!

### Shield-Kon® RSK Connectors

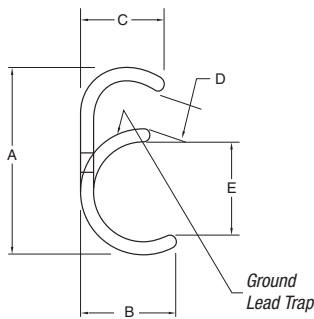
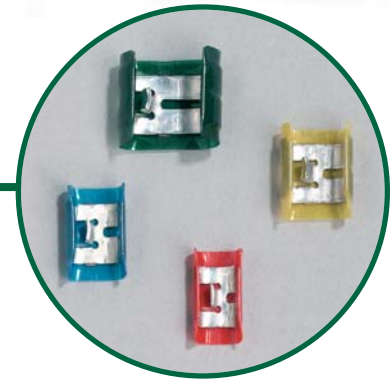





#### How to use connector die and tool selection chart:

1. Use a calibrated measuring tool lightly over shield for most accurate measurement. Rotate shielded wire to pick up high spots on cable. Use "Shield Diameter" column to match the measured dimension.
2. Select connector and die for ERG740 tool.

**NOTE:** 1. Do not solder-dip ends of ground leads.  
2. For ground wire combinations not covered in table, consult Technical Service.

### One-Piece Shield-Kon® Connectors & Die Selection Table

CONNECTOR & COLOR CAT. NO.	SHIELD DIAMETER	METAL DIES FOR ERG740	GROUND WIRE RANGE	DIE GAUGE CAT. NO.	APPLICATION TOOL CAT. NO.
 <b>RSK101</b> <b>Red</b>	(1.27–1.78 mm) .050–.070 in.	<b>D-101A</b>	1 or 2 #24 AWG STR or 1 #22 AWG STR	<b>101AG</b>	Hand Tool <b>ERG740</b>
	(1.80–2.26 mm) .071–.089 in.	<b>D-101B</b>		<b>101BG</b>	
 <b>RSK201</b> <b>Blue</b>	(2.29–2.54 mm) .090–.100 in.	<b>D-201C</b>	1 or 2 #22 AWG STR or 1 #20 AWG STR	<b>201CG</b>	
	(2.56–3.00 mm) .101–.118 in.	<b>D-201D</b>		<b>201DG</b>	
	(3.022–3.33 mm) .119–.131 in.	<b>D-201E</b>		<b>201EG</b>	
	(3.35–3.63 mm) .132–.143 in.	<b>D-201F</b>		<b>201FG</b>	
 <b>RSK301</b> <b>Yellow</b>	(3.66–4.11 mm) .144–.162 in.	<b>D-301G</b>	1 or 2 #22 AWG STR or 1 or 2 #20 AWG STR	<b>301GG</b>	
	(4.14–4.70 mm) .163–.185 in.	<b>D-301H</b>		<b>301HG</b>	
	(4.72–5.10 mm) .186–.201 in.	<b>D-301J</b>		<b>301JG</b>	
 <b>RSK401</b> <b>Green</b>	(5.13–5.84 mm) .202–.230 in.	<b>D-401K</b>	1 or 2 #20 AWG STR or 1 #18 AWG STR	<b>401KG</b>	
	(5.87–6.35 mm) .231–.250 in.	<b>D-401L</b>		<b>401LG</b>	
	(6.37–6.98 mm) .251–.275 in.	<b>D-401M</b>		<b>401MG</b>	
	(7.01–7.62 mm) .276–.300 in.	<b>D-401N</b>		<b>401NG</b>	

CAT. NO.	COLOR	DIMENSIONS (IN.)					THICKNESS	STD. PKG.
		A	B	C	D	E		
<b>RSK-101</b>	<b>Red</b>	.31	.16	.18	.06	.15	.02	1,000
<b>RSK-201</b>	<b>Blue</b>	.38	.22	.18	.06	.18	.02	1,000
<b>RSK-301</b>	<b>Yellow</b>	.47	.28	.24	.07	.22	.03	1,000
<b>RSK-401</b>	<b>Green</b>	.69	.43	.37	.08	.37	.03	500

Order multiple is std. pkg.