

KEYLESS FIXTURE LAMPHOLDERS

Phenolic
Medium Base E26



INCANDESCENT



2052



3352



2052-032 with BA-16351 cover, Type A-1 bracket



3354

Phenolic Keyless Fixture Lampholders

Cat. No. 2052 Series: Phenolic body. Aluminum screw shell. Standard leads are No. 18 ga. 105°C AWM-TEW plastic insulated wire, 6" long, stripped 3/4". Other wire specifications available. Insulating cover attached on request. Also available less leads, with eyelets for soldering (UL component listing). Available with 3/8" wide pad, less bracket, on request. Copper-alloy, nickel plated screw shell also available.

Standard pack: bulk

Cat. No. 2052 with Cover: 2052 series with phenolic cover, to comply with UL safety standard for electrical toys. Cover #BA-16351 accepts #18-2 SPT-1 wire. Covers accept all brackets used with 2052 series.

Cat. No. 2052 Series

- 660W-250V • UL Listed E-3810
- CSA Certified LR-1863 • NOM Certified 057

Cat. No. 3352: Same as 2052 series, but with screw terminals, backed out and staked. Body has wireways. Insulating cover available on request.

Cat. No. 3354: Same as 2052, but with quick-connect tabs: (1) 1/4" tab to center contact, (1) 3/16" tab to screw shell.

Cat. Nos. 3352 & 3354

- 660W-250V • UL Listed E-3810
- CSA Certified LR-1863 • NOM Certified 057

Brackets shown on pages E6-E8.

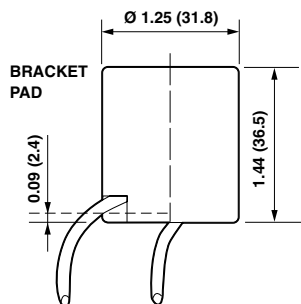

Cat. No. 2052

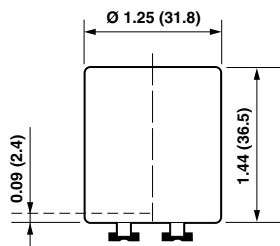

Cat. No. 3352

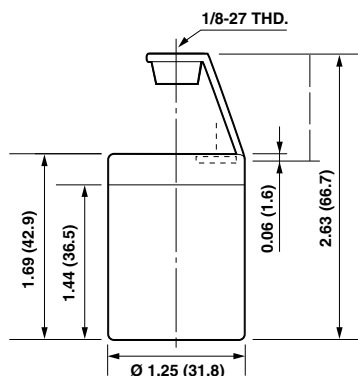

Cat. No. 2052-032
Shown with Optional Cover