

PCJ Polycarbonate Enclosures - NEMA 4X

PCJ Series

PCJ Series comes standard with patented multi-mounting capability including an out-of-the-box mounting flange or adjustable mounting feet which adapt to various mounting configurations. Featuring metallic or nonmetallic latches and molded-in latch keepers and mounting bosses, a tongue and groove seal joint between cover and base, PCJ is the ultimate in polycarbonate enclosures. A clear polycarbonate cover option is also available for instrumentation applications where critical electronic equipment must be visible and protected from the elements.



- Cover to base design – Flush, aesthetically pleasing and more modern architecture, moulded RAL7035 light gray
- Clear polycarbonate instrumentation cover where critical electrical/ electronic equipment must be visible and protected from the elements
- Solid/opaque covers available
- Operating temperatures between 130°C and -35°C (226°F to -31°F)
- Impact index of 16J (12ft/lb)
- Inner panels available in white painted steel or natural aluminium



- Metal or nonmetal snap latches mount on a molded-in boss and the latch to molded-in keepers with no additional wall penetrations.
- Padlock hasp comes standard on all snap latches.



- Out-of-the-box flange design - factory installed.
- Mounting dimensions molded into the enclosure base.
- Durable polycarbonate feet/flanges resist cracking during wall mount assembly.



- Feet and flanges act as an enclosure pad on uneven surfaces preventing enclosure from being drawn down and binding.
- Optional foot mount brackets for multi-directional mounting (vertical or horizontal positioning).



- Molded hinge design with stainless steel tamper resistant hinge pin with no wall penetrations.
- Tongue and groove, closed cell neoprene seal design achieves NEMA Type 4X rating.



- Molded-in back panel bosses with brass inserts and additional center bosses for mounting DIN rail using #10 sheet metal screws.



- Adjustable corner support allows panel to be flush to enclosure body or 1.5" from bottom within the moulded-in corner slots. Corner support supplied with optional swing panel assembly.

Panel
Sold
Separately



PCJ Polycarbonate Enclosures - NEMA 4X

PCJ Series

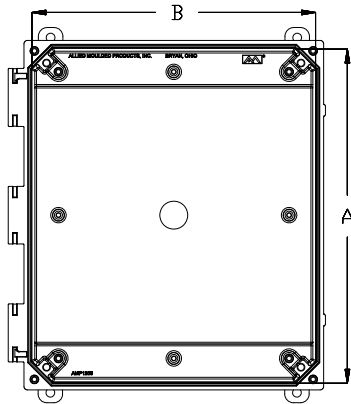

NOTE: COVER REMOVED FOR CLARITY

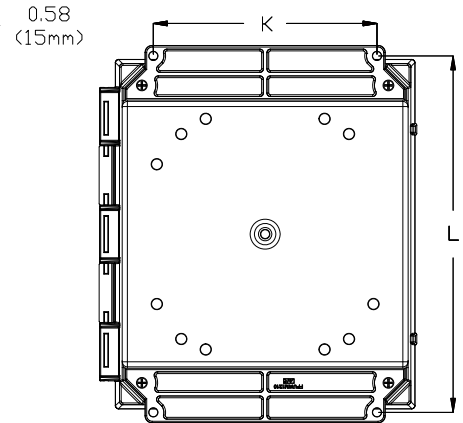
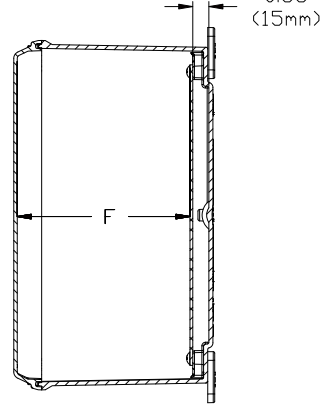

FLANGE MOUNT

Standards

- UL 508 Type 1, 2, 3, 4, 4X, 12 and 13
- CSA Type 1, 2, 3, 4, 4X, 12 and 13

Complies with

- NEMA Type 1, 2, 3, 4, 4X, 12 and 13
- IEC 60529, IP66
- Flamability V-O per UL 94
- UV rating (f1) per UL746C - UV stabilized for outdoor use
- Compliant with RoHS directive

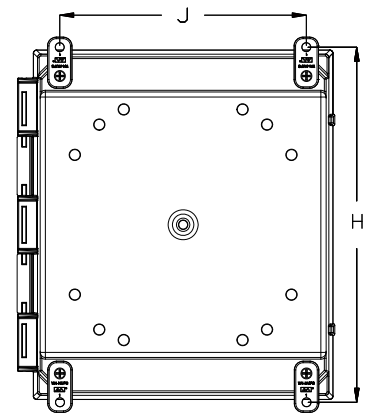
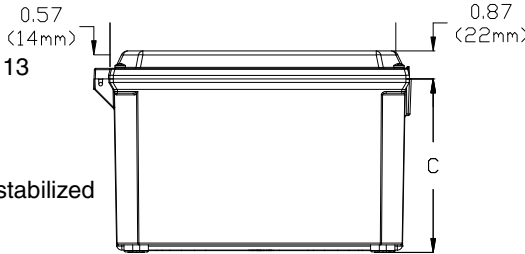

FOOT MOUNT

Base Enclosure Dimensions

Overall Dimensions			Feet Mounting Centers			Flange Mounting Centers		Nominal Wall Thickness
A	B	C	J	H	F	K	L	
5.93	6.16	3.98	4.91	6.75	4.18	4	6.88 / 6.75	0.14
7.94	6.16	3.98	4.91	8.75	4.18	4	8.88 / 8.75	0.14
9.93	8.15	3.98	6.91	10.75	4.18	6	10.75	0.14
11.92	10.15	5.98	8.82	12.7	6.18	8	12.75	0.14
13.94	12.16	5.98	10.82	14.7	6.18	10	14.75 / 14.62	0.14

Inner Panels, PCJ Series (optional)

Mild Steel Part No.	Aluminum Part No.	Panel		For Use With PCJ Series	
		Length	Width	A	B
PCJR0505	PCJA0505	4.81	4.81	5.93	6.16
PCJR0705	PCJA0705	6.75	4.88	7.94	6.16
PCJR0907	PCJA0907	8.75	6.88	9.93	8.15
PCJR1109	PCJA1109	10.75	8.88	11.92	10.15
PCJR1311	PCJA1311	12.75	10.88	13.94	12.16

Modification Services

Whether you require an additional cutout or accessories, Hammond has you covered!

- Holes
- Cutouts
- Accessory Installation

Call Today!

CAN: 519.822.2960
USA: 716.630.7030